

FP-108-FT/DC

60 x 60 x 10 mm

DESIGN FEATURES

- * **Bearing System:**
Ball bearing & sleeve bearing
- * **Impeller:**
Plastic with fiber glass filed UL 94V-0
- * **Housing:**
Plastic with fiber glass filed UL 94V-0
- * **Motor:**
Brushless DC
- * **Connecting:**
Wire leads
- * **Speed:**
S-1 high speed type
S-2 medium speed type
S-3 low speed type
- * Available FG Type for Speed Sensor Signal



Dimensions: mm

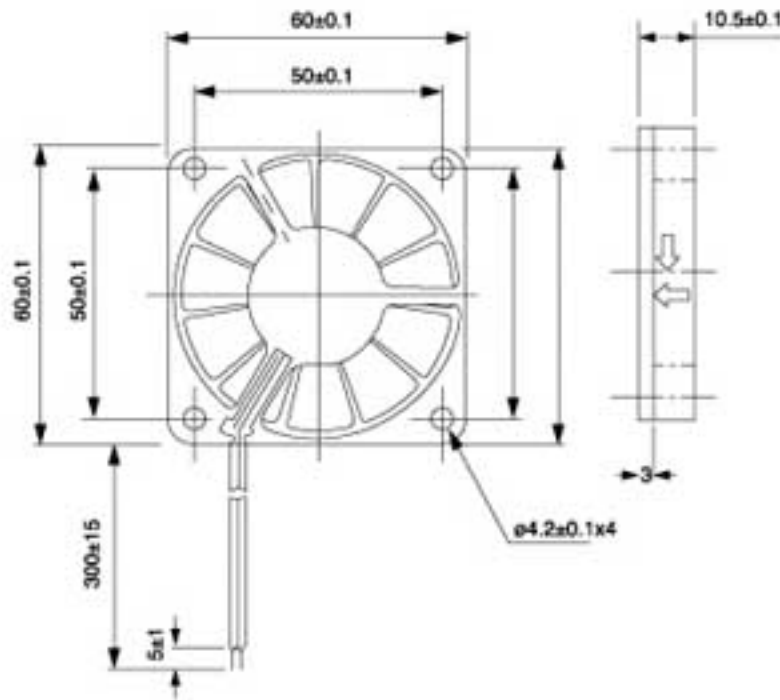

Performance

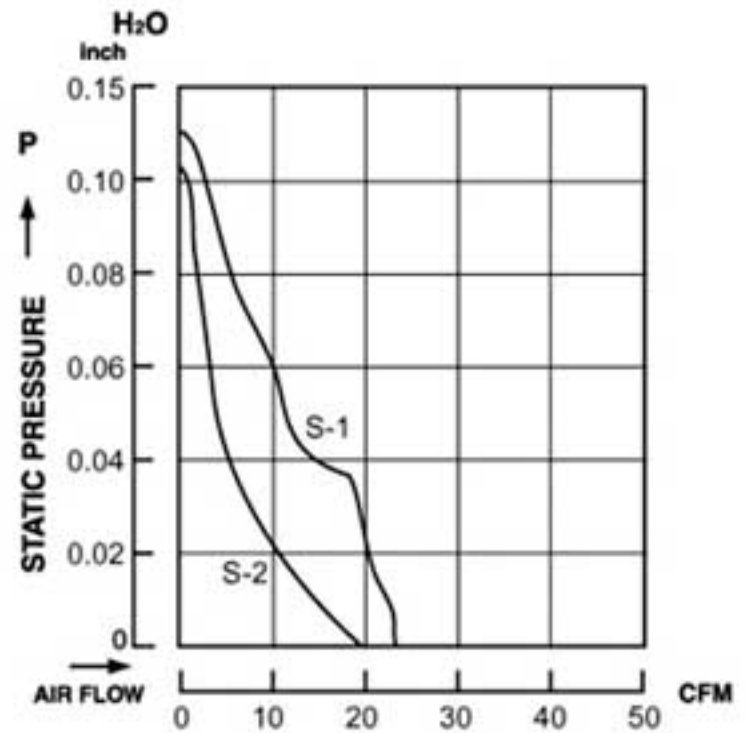

Specifications

MODEL NO.	VOLTAGE (VDC)	AIR (CFM)	VOLUME (M ³ /MIN)	CURRENT (A)	POWER (W)	SPEED (RPM)	STATIC PRESSURE (INCH-H ₂ O)	NOISE (dBA)
FP-108FT/DC (S-1)	12	23.50	0.66	0.21	2.52	4700	0.13	35
FP-108FT/DC (S-2)	12	20.00	0.60	0.16	1.92	4200	0.112	31