

SPECIFICATIONS

CUSTOMER	:	
SAMPLE CODE	:	SG320240WRMDBAI30Q
MASS PRODUCTION CODE	:	PG320240WRMDBAI30Q
SAMPLE VERSION	:	02
SPECIFICATIONS EDITION	:	003
DRAWING NO. (Ver.)	:	JLMD-PG320240WRMDBAI30Q_001
PACKAGING NO. (Ver.)	:	JPKG-PG320240WRMDBAI30Q_001

Customer Approved

Date:

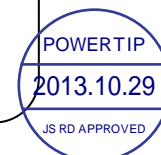

Approved	Checked	Designer
閔偉	張久慧	劉進

- Preliminary specification for design input
- Specification for sample approval

POWERTIP TECH. CORP.

Headquarters: No.8, 6 th Road, Taichung Industrial Park, Taichung, Taiwan 台中市 407 工業區六路 8 號	TEL: 886-4-2355-8168 FAX: 886-4-2355-8166	E-mail: sales@powertip.com.tw Http://www.powertip.com.tw
---	--	--

RECORDS OF REVISION

Date (mm / dd / yyyy)	Ver.	Edi.	Description	Page	Design by
06/25/2013	01	001	New Drawing	-	趙冬冬
08/22/2013	01	002	Sample Specification	-	劉進
10/21/2013	02	003	Modify Jumper: JMS (2) →JMS (1)	18	劉進

Total : 27 pages

Contents

1. SPECIFICATIONS

- 1.1 Features
- 1.2 Mechanical Specifications
- 1.3 Absolute Maximum Ratings
- 1.4 DC Electrical Characteristics
- 1.5 Optical Characteristics
- 1.6 Backlight Characteristics

2. MODULE STRUCTURE

- 2.1 Counter Drawing
- 2.2 Interface Pin Description
- 2.3 Timing Characteristics
- 2.4 Display Command
- 2.5 Jumper

3. QUALITY ASSURANCE SYSTEM

- 3.1 Quality Assurance Flow Chart
- 3.2 Inspection Specification

4. RELIABILITY TEST

- 4.1 Reliability Test Condition

5. PRECAUTION RELATING PRODUCT HANDLING

- 5.1 Safety
- 5.2 Handling
- 5.3 Storage
- 5.4 Terms of Warranty

Appendix: 1. LCM Drawing
2. LCM Packaging

Note : For detailed information please refer to IC data sheet : RAIO RA8835

1. SPECIFICATIONS

1.1 Features

Item	Standard Value
Display Type	320*240 dots
LCD Type	STN,Blue, Negative, Transmissive
Driver Condition	LCD Module : 1/240 Duty · 1/16Bias
Viewing Direction	6 O'clock
Backlight	LED Back Light
Weight	260g
Interface	8 bits parallel data input
Other(controller / driver IC)	RA8835
ROHS	THIS PRODUCT CONFORMS THE ROHS OF PTC Detail information please refer web site : http://www.powertip.com.tw/news.php?area_id_view=1085560481/

1.2 Mechanical Specifications

Item	Standard Value	Unit
Outline Dimension	153.54(L) * 120.24(w) * 21.0(H)(Max)	mm
Viewing Area	120.14(L) * 92.14(w)	mm
Active Area	115.18(L) * 86.38(w)	mm
Dot Size	0.34(L) * 0.34(w)	mm
Dot Pitch	0.36 (L) *.36(w)	mm

Note : For detailed information please refer to LCM drawing

1.3 Absolute Maximum Ratings

Item	Symbol	Condition	Min.	Max.	Unit
Power Supply Voltage	V _{DD}	-	-0.3	+7.0	V
LCD Driver Supply Voltage	V _{DD} -V _{EE}	-	-0.3	32	V
Input Voltage	V _{IN}	-	-0.3	V _{DD} +0.3	V
Operating Temperature	T _{OP}	-	-20	70	°C
Storage Temperature	T _{ST}	-	-30	80	°C
Storage Humidity	H _D	Ta < 60 °C	-	90	%RH

1.4 DC Electrical Characteristics

$V_{DD} = 5.0\text{ V} \pm 5\%$, $V_{SS} = 0\text{ V}$, $T_a = 25^\circ\text{C}$

Item	Symbol	Condition	Min.	Typ.	Max.	Unit
Logic Supply Voltage	V_{DD}	-	4.75	5.0	5.25	V
“H” Input Voltage	V_{IH}	-	$0.5V_{DD}$	-	V_{DD}	V
“L” Input Voltage	V_{IL}	-	V_{SS}	-	$0.2V_{DD}$	V
“H” Output Voltage	V_{OH}	$IOH=4\text{mA}$	2.4	-	-	V
“L” Output Voltage	V_{OL}	$IOL=-2\text{mA}$	-	-	$V_{SS}+0.4$	V
Supply Current	I_{DD}	$V_{DD}=5.0\text{V}; V_{OP}=22.1\text{V};$ Pattern= Horizontal *1	-	45	100	mA
LCM Driver Voltage	V_{OP}^*2	-20°C	22.5	22.7	22.9	V
		25°C	21.9	22.1	22.3	
		70°C	21.4	21.6	21.8	

NOTE: *1 The Maximum current display;

*2 The VOP test point is $V_{op+} \sim V_{op-}$

1.5 Optical Characteristics

Ta =25°C

Item		Symbol	Conditions	Min.	Typ.	Max.	Unit	Reference
Response Time	Rise	tr	-	-	240	360	ms	Note2
	Fall	tf		-	130	195		
Viewing angle range	Rear	$\theta+$	$C \geq 2.0$	40	-	-	Deg.	Notes 1
	Front	$\theta-$		40	-	-		
	Left	θL		45	-	-		
	Right	θR		45	-	-		
Contrast Ratio		C	-	-	5.7	-	-	Note 3
Average Brightness (with LCD) *2		IV	IF=160mA	20	30	-	cd/m ²	Note 4
CIE Color Coordinate (With LCD)*2		x		0.26	0.32	0.38	nm	
		y		0.28	0.34	0.40		
Uniformity *1		ΔB	-	70	-	-	%	

Note 4 :

1 : $\Delta B = B(\min) / B(\max) * 100\%$

2 : Measurement Condition for Optical Characteristics:

a : Environment: $25^{\circ}\text{C} \pm 5^{\circ}\text{C}$ / $60 \pm 20\%$ R.H , no wind , dark room below 10 Lux at typical lamp current and typical operating frequency.

b : Measurement Distance: 500 ± 50 mm , ($\theta = 0^{\circ}$)

c : Equipment: TOPCON BM-7 fast , (field 1°) , after 10 minutes operation.

d : The uncertainty of the C.I.E coordinate measurement ± 0.01 , Average Brightness $\pm 4\%$

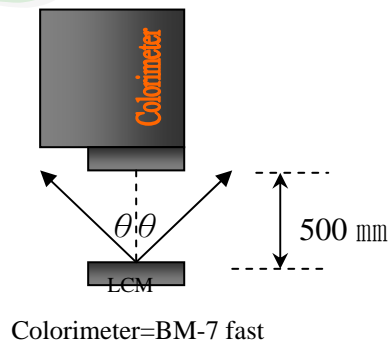
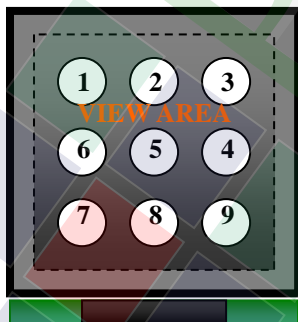

Note 1.

Optical characteristics-2

Viewing angle

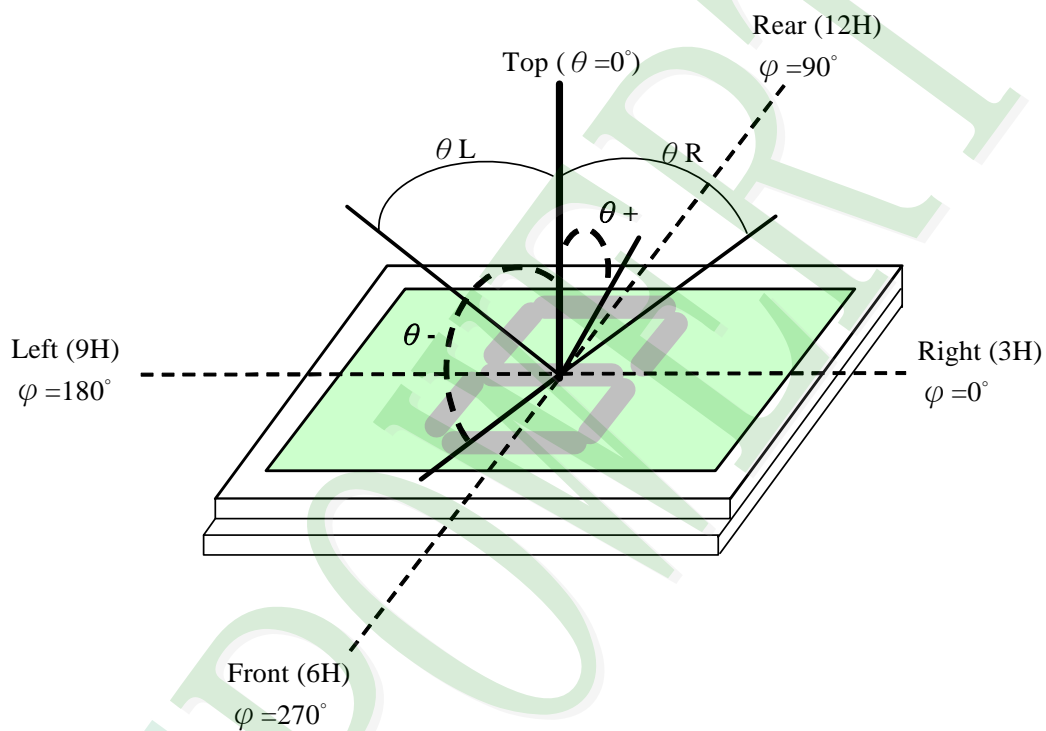

Viewing angle

Note 2.

Optical characteristics-3

Fig.2 Definition of response time

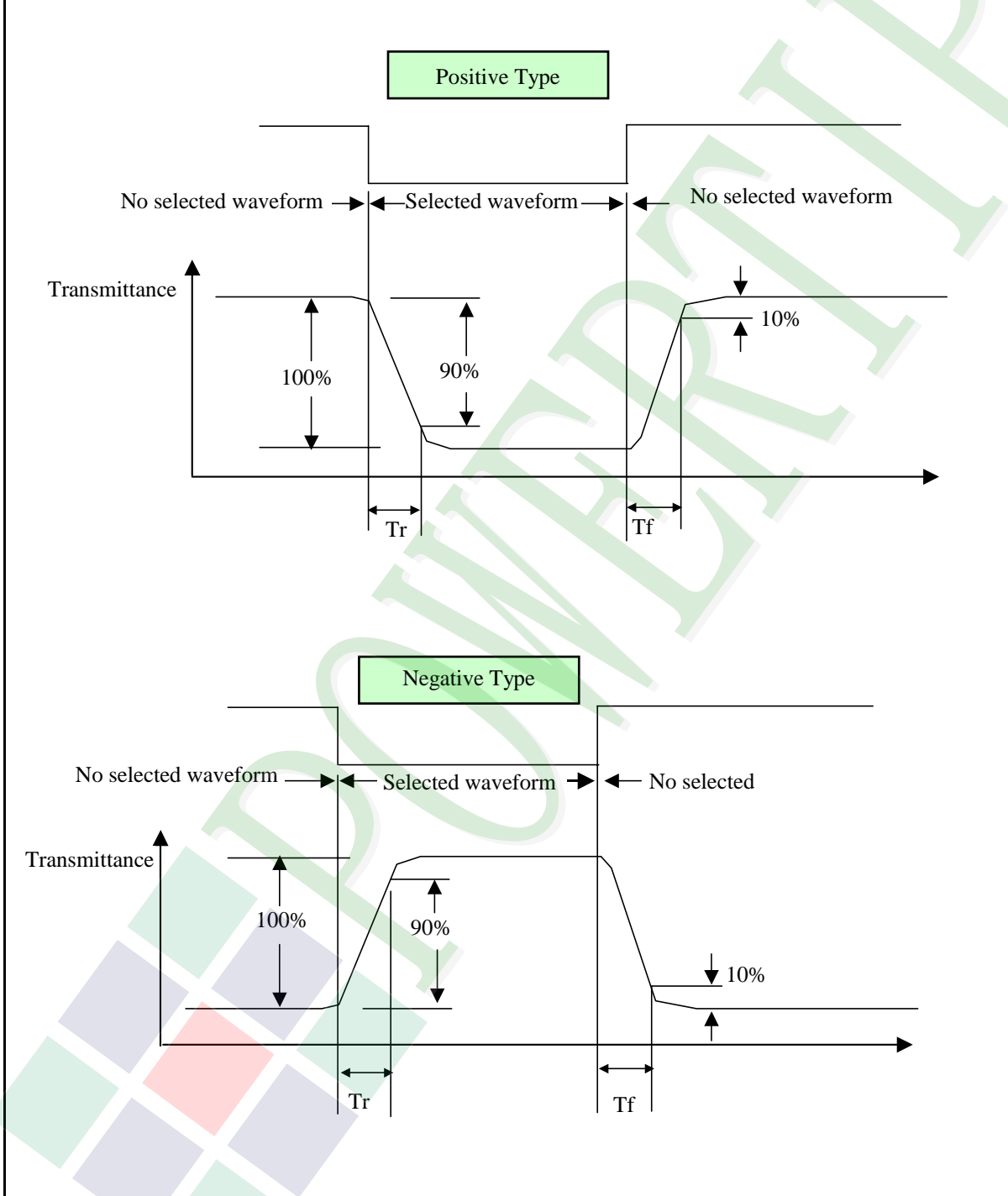

Electrical characteristics-2

※2 Drive waveform

V_{op} : Drive voltage

f_F : Frame frequency

$1/B$: Bias

f_D : Drive frequency

N : Duty

(1) Selected waveform

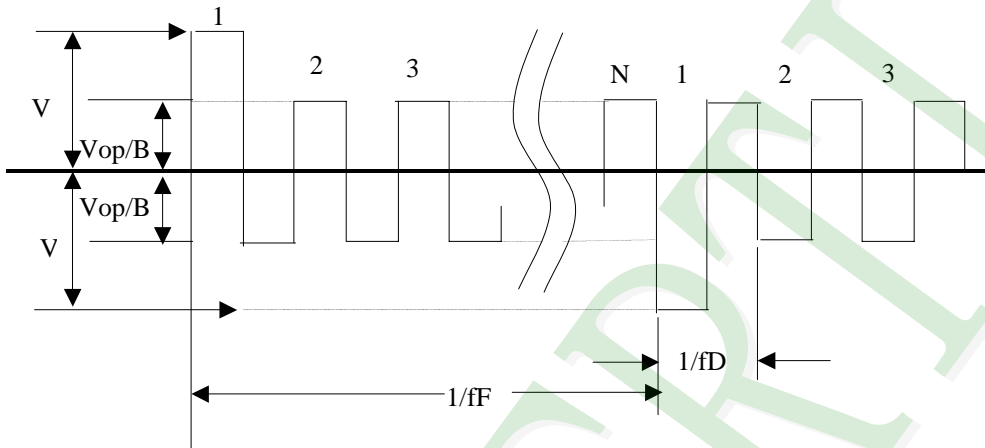

(2) Non- Selected wave form

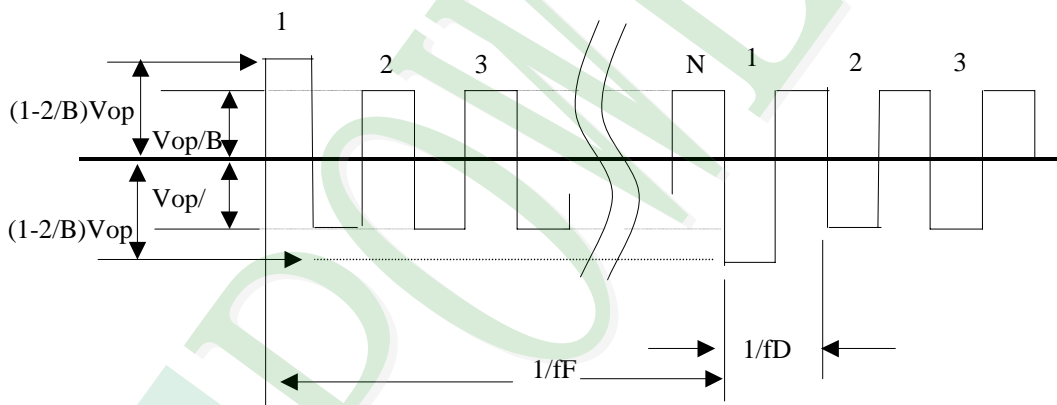

Note:

Frame frequency is defined as follows: Common side supply voltage peak - to - peak / 2 = 1 period

Note 3. : Definition of Vth

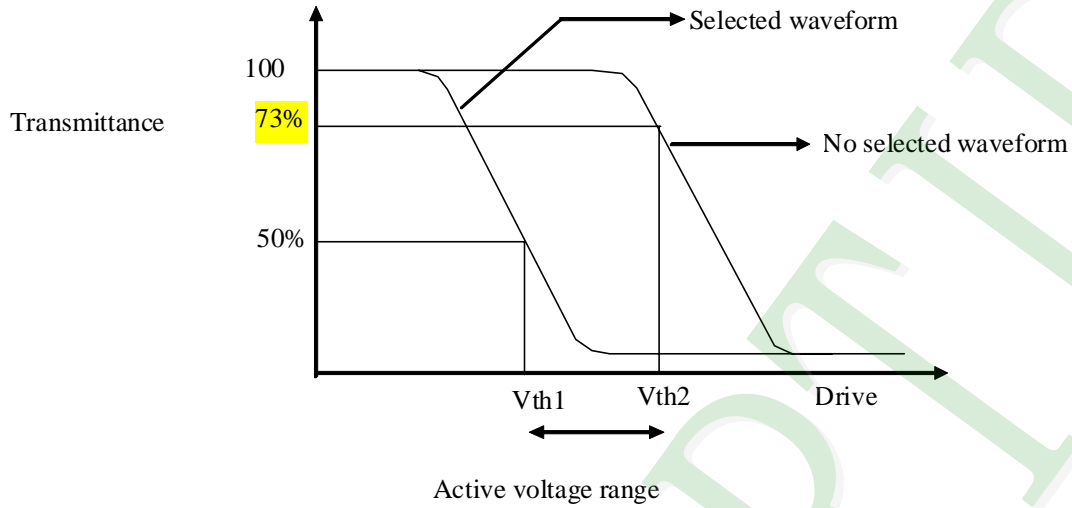

	Vth1	Vth2
View direction	10°	40°
Drive waveform	(Selected waveform)	(No selected waveform)
Transmittance	50%	73%

※1 Contrast ratio
 = (Brightness in OFF state) / (Brightness in ON state)

Outline of Electro-Optical Characteristics Measuring System

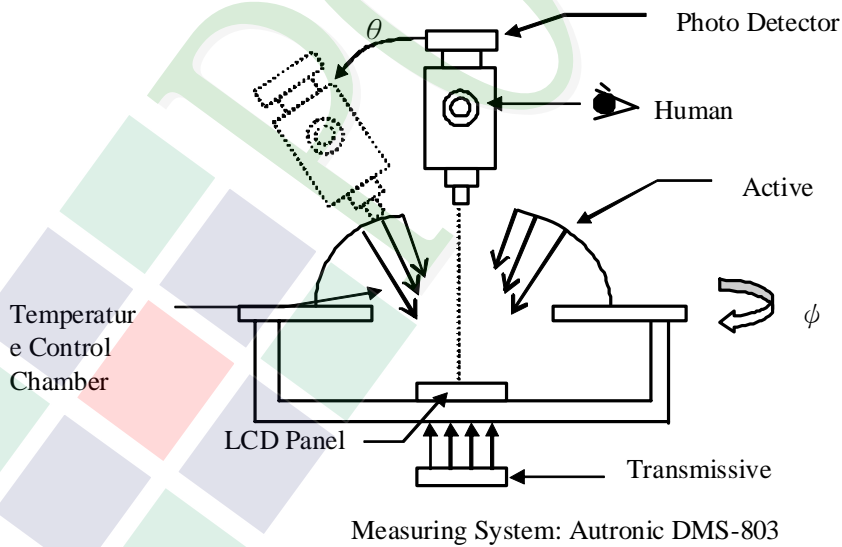

1.6 Backlight Characteristics

Maximum Ratings

Item	Symbol	Conditions	Min.	Max.	Unit
Forward Current	IF	Ta =25°C	-	160	mA
Reverse Voltage	VR	Ta =25°C	-	5	V
Reverse Current	IR	VR=5V	-	10	uA
Power Dissipation	PD	Ta =25°C	-	0.8	W

Electrical / Optical Characteristics

Item	Symbol	Conditions	Min.	Typ.	Max.	Unit
Forward Voltage	VF	IF=160mA	-	3.4	4.0	V
Average Brightness (without LCD)	IV		210	280	-	cd/m2
CIE Color Coordinate (without LCD)	X		0.25	0.28	0.31	
	Y		0.26	0.29	0.32	
Color	White					

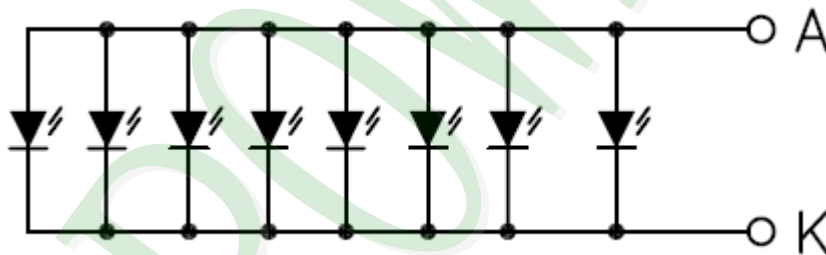

2. MODULE STRUCTURE

2.1 Counter Drawing

2.1.1 LCM Mechanical Diagram

* See Appendix

2.1.2 Block Diagram

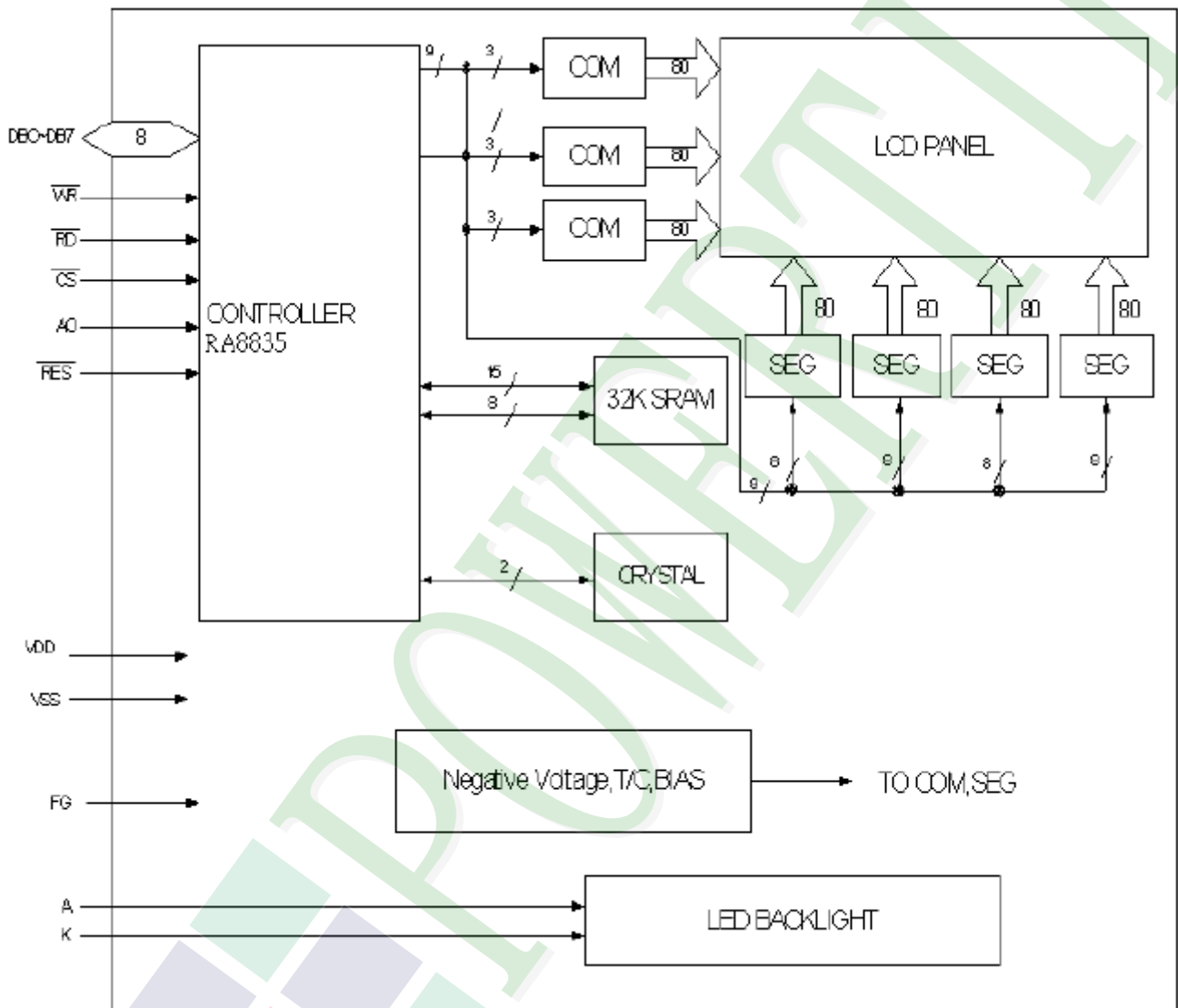

2.2 Interface Pin Description

Pin No.	Symbol	Function
1	VSS	Ground(V _{ss} =0V)
2	VDD	Power Supply
3	VLCD	Operating Voltage for LCD. Not connection.
4	/RD	Data read (read data from the module at "L")
5	/WR	Data write (write data to the module at "L")
6	A0	Command/Data read or write select (H:command L:data)
7	DB0	Data bus
8	DB1	Data bus
9	DB2	Data bus
10	DB3	Data bus
11	DB4	Data bus
12	DB5	Data bus
13	DB6	Data bus
14	DB7	Data bus
15	/CS	Chip select ,active "L"
16	/RES	Reset input ,active "L"
17	VEE	Negative voltage out. Not connection.
18	FG	Frame ground (connect to metal bezel)
19	NC	Not connection
20	NC	Not connection

Built in negative voltage generator circuit and temperature compensation circuit.

Built in Timing mode for 8080 family.

2.2.1 Refer Initial Code

```
write_com(0x40);           //initialize device and display
write_dat(0x30);
write_dat(0x87);
write_dat(0x07);
write_dat(39);
write_dat(65);
write_dat(239);
write_dat(0x28);
write_dat(0x00);

write_com(0x44);           //Set display start address and display regions
write_dat(0x00);
write_dat(0x00);
write_dat(0xef);
write_dat(0xb0);
write_dat(0x04);
write_dat(0xef);

write_com(0x5a);           //set number of pixels to scroll=0
write_dat(0x00);

write_com(0x5b);           //select layerd screen composition and screen text/graphics mode
write_dat(0x00);

write_com(0x58);           //set display off and display flashing
write_dat(0x14);

write_com(0x5d);           //set cursor type
write_dat(0x07);
write_dat(0x00);

write_com(0x59);           //set display on and display flashing
write_dat(0x14);
```

2.3 Timing Characteristics

8080 Family Interface Timing

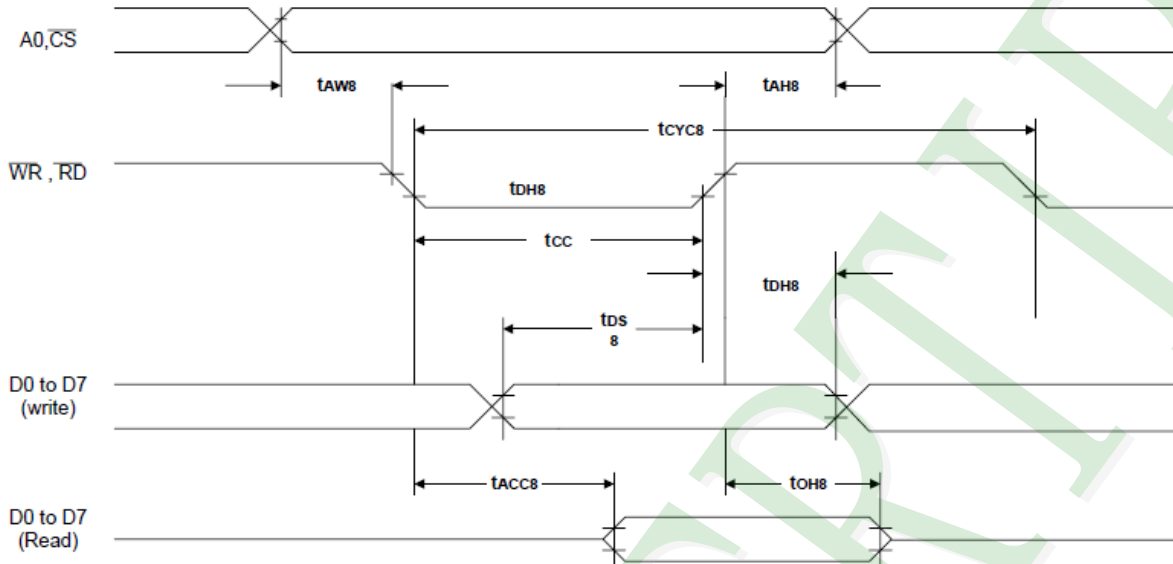

T_a = -20 to 75°C

Signal	Symbol	Parameter	V _{DD} = 4.5 to 5.5V		V _{DD} = 2.7 to 4.5V		Unit	Condition
			Min.	Max.	Min.	Max.		
A0, \overline{CS}	t _{AH8}	Address hold time	10	—	10	—	ns	CL = 100pF
	t _{AW8}	Address setup time	0	—	0	—	ns	
\overline{WR} , \overline{RD}	t _{CYC8}	System cycle time	note.	—	note.	—	ns	
	t _{CC}	Strobe pulse width	120	—	150	—	ns	
D0 to D7	t _{DS8}	Data setup time	120	—	120	—	ns	
	t _{DH8}	Data hold time	5	—	5	—	ns	
	t _{ACC8}	\overline{RD} access time	—	50	—	80	ns	
	t _{OH8}	Output disable time	10	50	10	55	ns	

Note: For memory control and system control commands:

$$t_{CYC8} = 2t_c + t_{CC} + t_{CEA} + 75 > t_{ACV} + 245$$

For all other commands:

$$t_{CYC8} = 4t_c + t_{CC} + 30$$

Reset Timing

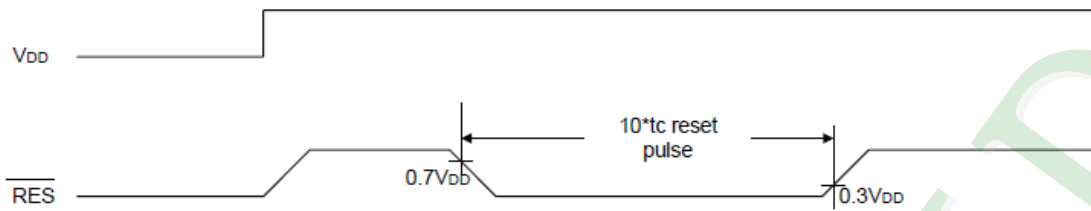

Reset Timing

The RA8835A series requires a reset pulse at least $10 \cdot t_c$ long after power-on in order to re-initialize its internal state. If the oscillator frequency is 10MHz, then the Reset pulse is at least $1\mu s$. For maximum reliability, it is not recommended to apply a DC voltage to the LCD panel while the RA8835A series is reset. Turn off the LCD power supplies for at least one frame period after the start of the reset pulse.

The RA8835A series cannot receive commands while it is reset. Commands to initialize the internal registers should be issued soon after a reset. During reset, the LCD drive signals XD, LP and FR are halted. A delay of 3 ms (maximum) is required following the rising edges of both RES and VDD to allow for system stabilization.

2.4 Display Command

Class	Command	Code											Hex	Command Description	Command Read Parameters	
		RD	WR	A0	D7	D6	D5	D4	D3	D2	D1	D0			No. of Bytes	Section
System Control	SYSTEM SET	1	0	1	0	1	0	0	0	0	0	0	40	Initialize device and display	8	9-2-1
	SLEEP IN	1	0	1	0	1	0	1	0	0	1	1	53	Enter standby mode	0	9-2-2
Display Control	DISPLAY ON/OFF	1	0	1	0	1	0	1	1	0	0	D	58, 59	Enable and disable display and display flashing	1	9-3-1
	SCROLL	1	0	1	0	1	0	0	0	1	0	0	44	Set display start address and display regions	10	9-3-2
	CSRFORM	1	0	1	0	1	0	1	1	1	0	1	5D	Set cursor type	2	9-3-3
	CGRAM ADR	1	0	1	0	1	0	1	1	1	0	0	5C	Set start address of character generator RAM	2	9-3-6
	CSRDIR	1	0	1	0	1	0	0	1	1	CD	CD	4C to 4F	1	0	9-3-4
	HDOT SCR	1	0	1	0	1	0	1	1	0	1	0	5A	Set horizontal scroll position	1	9-3-7
	OVLAY	1	0	1	0	1	0	1	1	0	1	1	5B	Set display overlay format	1	9-3-5
Drawing Control	CSRW	1	0	1	0	1	0	0	0	1	1	0	46	Set cursor address	2	9-r1
	CSRR	1	0	1	0	1	0	0	0	1	1	1	47	Read cursor address	2	9-4-2
Memory Control	MWRITE	1	0	1	0	1	0	0	0	0	1	0	42	Write to display memory	—	9-5-1
	MREAD	1	0	1	0	1	0	0	0	0	1	1	43	Read from display memory	—	9-5-2

Notes:

1. In general, the internal registers of the RA8835A series are modified as each command parameter is input. However, the microprocessor does not have to set all the parameters of a command and may send a new command before all parameters have been input. The internal registers for the parameters that have been input will have been changed but the remaining parameter registers are unchanged. 2-byte parameters (where two bytes are treated as 1 data item) are handled as follows:

- a. CSRW, CSRR: Each byte is processed individually. The microprocessor may read or write just the low byte of the cursor address.
- b. SYSTEM SET, SCROLL, CGRAM ADR: Both parameter bytes are processed together. If the command is changed after half of the parameter has been input, the single byte is ignored.

2. APL and APH are 2-byte parameters, but are treated as two 1-byte parameters.

2.5 Jumper

Short : JMS (1) ,JP (2) ,JDS (1) ,JE1,JE2 ;

Open : All the jumper unnoted.



3. QUALITY ASSURANCE SYSTEM

3.1 Quality Assurance Flow Chart

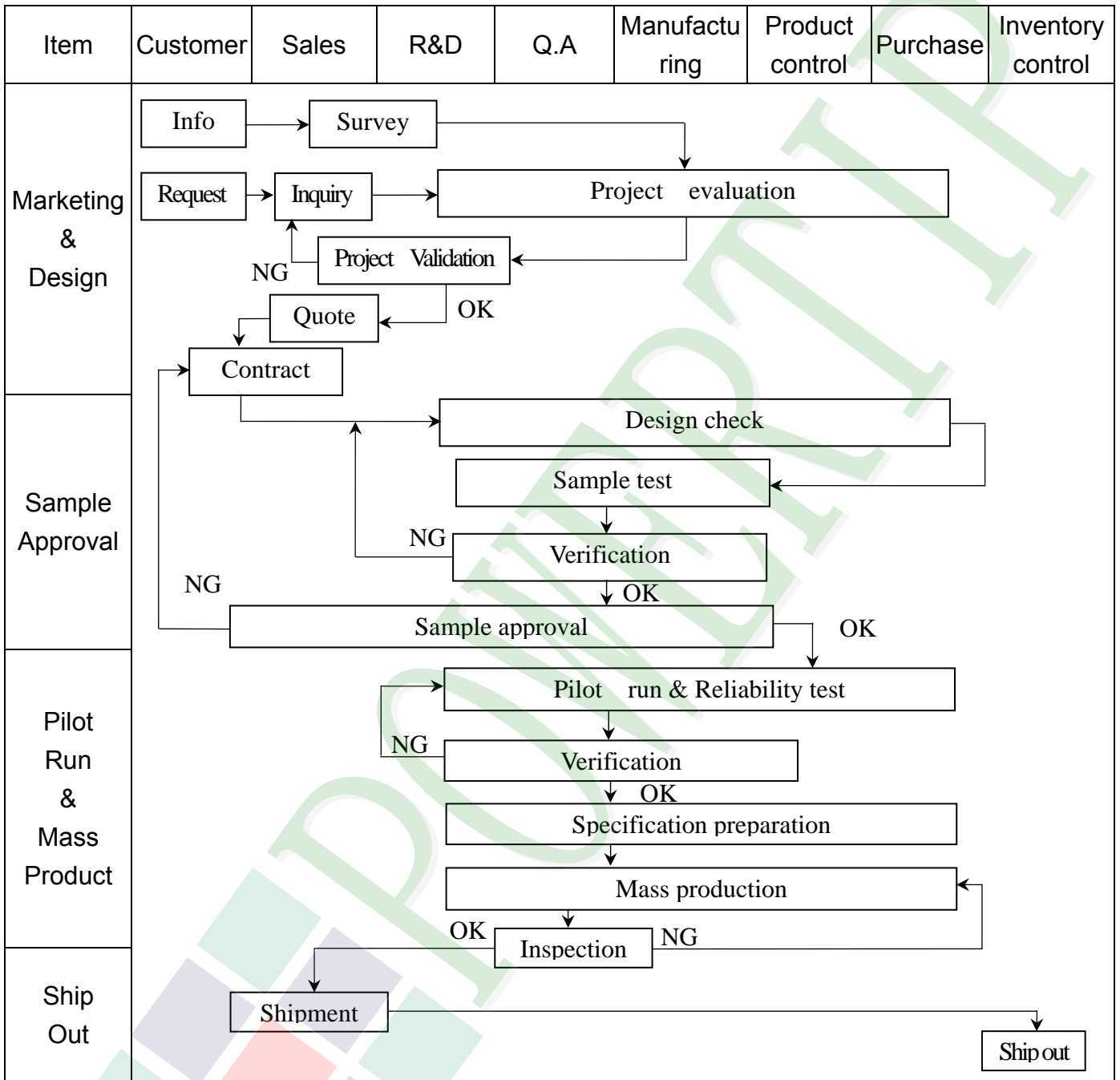

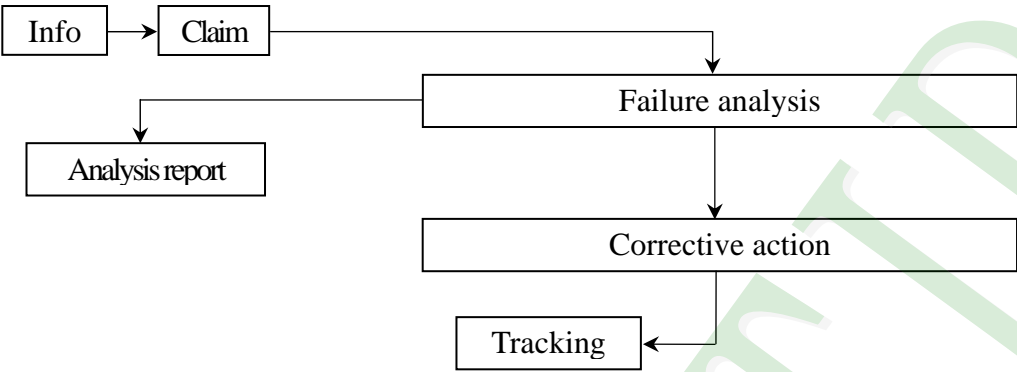
Item	Customer	Sales	R&D	Q.A	Manufacturing	Product control	Purchase	Inventory control
Sales Service	 <pre> graph TD Info[Info] --> Claim[Claim] Claim --> FA[Failure analysis] Claim --> AR[Analysis report] FA --> CA[Corrective action] CA --> Tracking[Tracking] </pre>							
Q.A Activity	1. ISO 9001 Maintenance Activities 3. Equipment calibration 5. Standardization Management				2. Process improvement proposal 4. Education And Training Activities			

3.2 Inspection Specification

◆ Scope : The document shall be applied to LCD Module for Monotype and Color STN(Ver. B01).

◆ Inspection Standard : MIL-STD-105E Table Normal Inspection Single Sampling Level II .

◆ Equipment : Gauge 、 MIL-STD 、 Powertip Tester 、 Sample

◆ Defect Level : Major Defect AQL : 0.4 ; Minor Defect : AQL : 1.5 .

◆ OUT Going Defect Level : Sampling .

◆ Manner of appearance test :

(1). The test be under 20W×2 fluorescent light ' and distance of view must be at 30 cm.

(2). Standard of inspection : (Unit : mm)

(3). The test direction is base on about around 45° of vertical line. (Fig. 1)

(4). Definition of area . (Fig. 2)

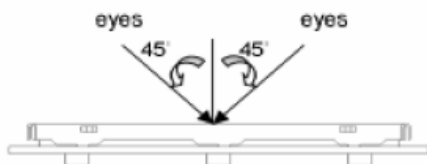

Fig.1

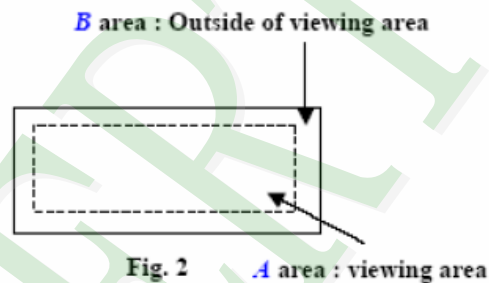
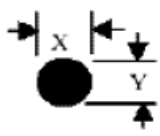
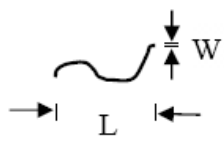
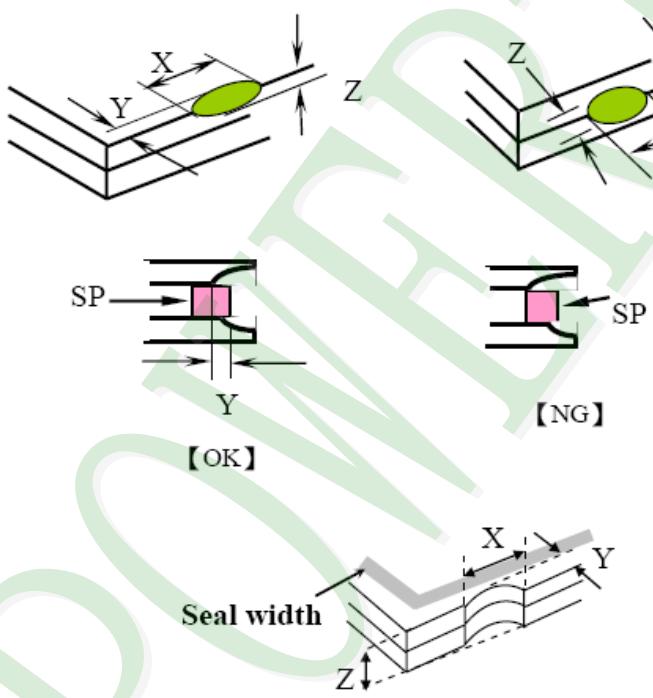

Fig. 2

◆ Specification:

NO	Item	Criterion	Level
01	Product condition	1. 1 The part number is inconsistent with work order of Production.	Major
		1. 2 Mixed production types.	Major
		1. 3 Assembled in inverse direction.	Major
02	Quantity	2. 1 The quantity is inconsistent with work order of production.	Major
03	Outline dimension	3. 1 Product dimension and structure must conform to Structure diagram.	Major
04	Electrical Testing	4. 1 Missing line character and icon.	Major
		4. 2 No function or no display.	Major
		4. 3 Output data is error.	Major
		4. 4 LCD viewing angle defect.	Major
		4. 5 Current consumption exceeds product specifications.	Major

NO	Item	Criterion	Level																																					
05	Black or white dot、scratch、contamination Round type  $\Phi = (x+y)/2$ Line type 	5. 1 Round type: 5. 1. 1 display only : • White and black spots on display ≤ 0.30 mm , no more than 4 white or black spots present. • Densely spaced : NO more than two spots or lines within 3 mm. 5. 1. 2 Non-display : <table border="1"> <thead> <tr> <th rowspan="2">Dimension (diameter : Φ)</th> <th colspan="2">Acceptance (Q'ty)</th> </tr> <tr> <th>A area</th> <th>B area</th> </tr> </thead> <tbody> <tr> <td>$\Phi \leq 0.10$</td> <td colspan="2">Accept no dense</td> </tr> <tr> <td>$0.10 < \Phi \leq 0.20$</td> <td>3</td> <td rowspan="2">Ignore</td> </tr> <tr> <td>$0.20 < \Phi \leq 0.30$</td> <td>2</td> </tr> <tr> <td>Total quantity</td> <td colspan="2">4</td> </tr> </tbody> </table> 5. 1. 3 Line type: <table border="1"> <thead> <tr> <th colspan="2">Dimension</th> <th colspan="2">Acceptance (Q'ty)</th> </tr> <tr> <th>Length (L)</th> <th>Width (W)</th> <th>A area</th> <th>B area</th> </tr> </thead> <tbody> <tr> <td>---</td> <td>$W \leq 0.03$</td> <td>Accept no dense</td> <td rowspan="3">Ignore</td> </tr> <tr> <td>$L \leq 3.0$</td> <td>$0.03 < W \leq 0.05$</td> <td rowspan="2">4</td> </tr> <tr> <td>$L \leq 2.5$</td> <td>$0.05 < W \leq 0.075$</td> </tr> <tr> <td>---</td> <td>$W > 0.075$</td> <td colspan="2">As round type</td> </tr> </tbody> </table>	Dimension (diameter : Φ)	Acceptance (Q'ty)		A area	B area	$\Phi \leq 0.10$	Accept no dense		$0.10 < \Phi \leq 0.20$	3	Ignore	$0.20 < \Phi \leq 0.30$	2	Total quantity	4		Dimension		Acceptance (Q'ty)		Length (L)	Width (W)	A area	B area	---	$W \leq 0.03$	Accept no dense	Ignore	$L \leq 3.0$	$0.03 < W \leq 0.05$	4	$L \leq 2.5$	$0.05 < W \leq 0.075$	---	$W > 0.075$	As round type		Minor
Dimension (diameter : Φ)	Acceptance (Q'ty)																																							
	A area	B area																																						
$\Phi \leq 0.10$	Accept no dense																																							
$0.10 < \Phi \leq 0.20$	3	Ignore																																						
$0.20 < \Phi \leq 0.30$	2																																							
Total quantity	4																																							
Dimension		Acceptance (Q'ty)																																						
Length (L)	Width (W)	A area	B area																																					
---	$W \leq 0.03$	Accept no dense	Ignore																																					
$L \leq 3.0$	$0.03 < W \leq 0.05$	4																																						
$L \leq 2.5$	$0.05 < W \leq 0.075$																																							
---	$W > 0.075$	As round type																																						
06	Polarizer Bubble	<table border="1"> <thead> <tr> <th rowspan="2">Dimension (diameter : Φ)</th> <th colspan="2">Acceptance (Q'ty)</th> </tr> <tr> <th>A area</th> <th>B area</th> </tr> </thead> <tbody> <tr> <td>$\Phi \leq 0.20$</td> <td colspan="2">Accept no dense</td> </tr> <tr> <td>$0.20 < \Phi \leq 0.50$</td> <td>3</td> <td rowspan="3">Ignore</td> </tr> <tr> <td>$0.50 < \Phi \leq 1.00$</td> <td>2</td> </tr> <tr> <td>$\Phi > 1.00$</td> <td>0</td> </tr> <tr> <td>Total quantity</td> <td colspan="2">4</td> </tr> </tbody> </table>	Dimension (diameter : Φ)	Acceptance (Q'ty)		A area	B area	$\Phi \leq 0.20$	Accept no dense		$0.20 < \Phi \leq 0.50$	3	Ignore	$0.50 < \Phi \leq 1.00$	2	$\Phi > 1.00$	0	Total quantity	4		Minor																			
Dimension (diameter : Φ)	Acceptance (Q'ty)																																							
	A area	B area																																						
$\Phi \leq 0.20$	Accept no dense																																							
$0.20 < \Phi \leq 0.50$	3	Ignore																																						
$0.50 < \Phi \leq 1.00$	2																																							
$\Phi > 1.00$	0																																							
Total quantity	4																																							

NO	Item	Criterion	Level						
07	The crack of glass	<p>Symbols :</p> <p>X : The length of crack Z : The thickness of crack t : The thickness of glass</p> <p>Y : The width of crack. W : terminal length a : LCD side length</p>	Minor						
		<p>7.1 General glass chip :</p> <p>7.1.1 Chip on panel surface and crack between panels:</p>  <table border="1" data-bbox="507 1489 1311 1780"> <thead> <tr> <th>X</th> <th>Y</th> <th>Z</th> </tr> </thead> <tbody> <tr> <td>$\leq a$</td> <td>Crack can't enter viewing area</td> <td>$\leq 1/2 t$</td> </tr> <tr> <td>$\leq a$</td> <td>Crack can't exceed the half of SP width.</td> <td>$1/2 t < Z \leq 2 t$</td> </tr> </tbody> </table>		X	Y	Z	$\leq a$	Crack can't enter viewing area	$\leq 1/2 t$
X	Y	Z							
$\leq a$	Crack can't enter viewing area	$\leq 1/2 t$							
$\leq a$	Crack can't exceed the half of SP width.	$1/2 t < Z \leq 2 t$							

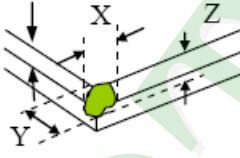
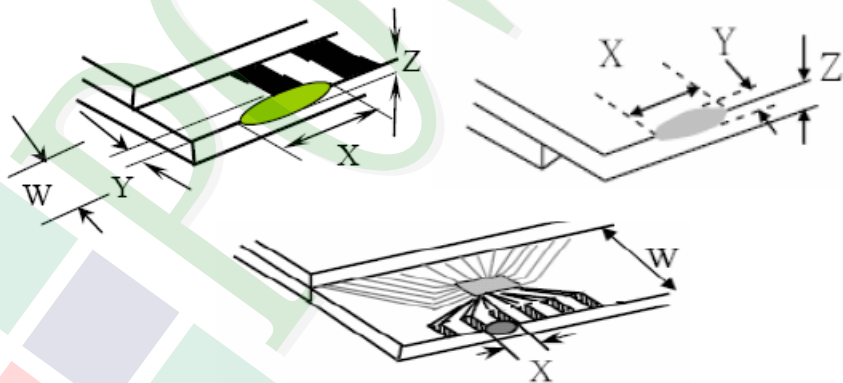
NO	Item	Criterion	Level									
07	The crack of glass	<p>Symbols :</p> <p>X : The length of crack Y : The width of crack. Z : The thickness of crack W : terminal length t : The thickness of glass a : LCD side length</p> <hr/> <p>7.1.2 Corner crack :</p>  <table border="1" data-bbox="507 801 1321 1093"> <thead> <tr> <th>X</th> <th>Y</th> <th>Z</th> </tr> </thead> <tbody> <tr> <td>$\leq 1/5 a$</td> <td>Crack can't enter viewing area</td> <td>$Z \leq 1/2 t$</td> </tr> <tr> <td>$\leq 1/5 a$</td> <td>Crack can't exceed the half of SP width.</td> <td>$1/2 t < Z \leq 2 t$</td> </tr> </tbody> </table>	X	Y	Z	$\leq 1/5 a$	Crack can't enter viewing area	$Z \leq 1/2 t$	$\leq 1/5 a$	Crack can't exceed the half of SP width.	$1/2 t < Z \leq 2 t$	Minor
		X	Y	Z								
$\leq 1/5 a$	Crack can't enter viewing area	$Z \leq 1/2 t$										
$\leq 1/5 a$	Crack can't exceed the half of SP width.	$1/2 t < Z \leq 2 t$										
<p>7.2 Protrusion over terminal :</p> <p>7.2.1 Chip on electrode pad :</p>  <table border="1" data-bbox="475 1675 1257 1848"> <thead> <tr> <th></th> <th>X</th> <th>Y</th> <th>Z</th> </tr> </thead> <tbody> <tr> <td>Front</td> <td>$\leq a$</td> <td>$\leq 1/2 W$</td> <td>$\leq t$</td> </tr> <tr> <td>Back</td> <td colspan="3">Neglect</td> </tr> </tbody> </table>		X	Y	Z	Front	$\leq a$	$\leq 1/2 W$	$\leq t$	Back	Neglect		
	X	Y	Z									
Front	$\leq a$	$\leq 1/2 W$	$\leq t$									
Back	Neglect											

◆ Specification For Monotype and Color STN :

(Ver. B01)

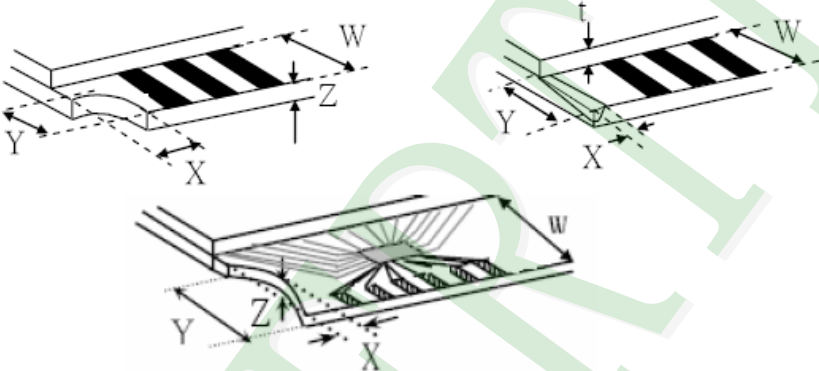
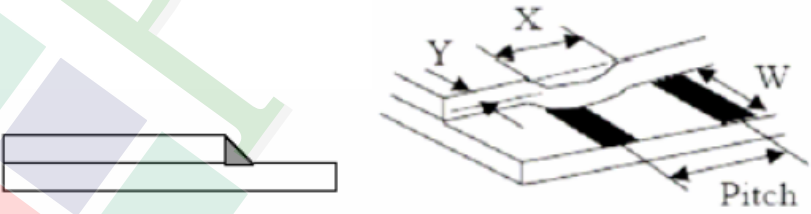
NO	Item	Criterion	Level									
07	The crack of glass	<p>Symbols :</p> <p>X : The length of crack Z : The thickness of crack t : The thickness of glass</p> <p>Y : The width of crack. W : terminal length a : LCD side length</p>	Minor									
		<p>7.2.2 Non-conductive portion :</p>  <table border="1" data-bbox="587 1037 1214 1189"> <thead> <tr> <th>X</th> <th>Y</th> <th>Z</th> </tr> </thead> <tbody> <tr> <td>$\leq 1/3 a$</td> <td>$\leq W$</td> <td>$\leq t$</td> </tr> </tbody> </table> <p>⊙ If the chipped area touches the ITO terminal, over 2/3 of the ITO must remain and be inspected according to electrode terminal specifications.</p> <p>7.2.3 Glass remain :</p>  <table border="1" data-bbox="509 1715 1195 1856"> <thead> <tr> <th>X</th> <th>Y</th> <th>Z</th> </tr> </thead> <tbody> <tr> <td>$\leq a$</td> <td>$\leq 1/3 W$</td> <td>$\leq t$</td> </tr> </tbody> </table>		X	Y	Z	$\leq 1/3 a$	$\leq W$	$\leq t$	X	Y	Z
X	Y	Z										
$\leq 1/3 a$	$\leq W$	$\leq t$										
X	Y	Z										
$\leq a$	$\leq 1/3 W$	$\leq t$										

◆ Specification For Monotype and Color STN :

(Ver. B01)

NO	Item	Criterion	Level
08	Backlight elements	8. 1 Backlight can't work normally.	Major
		8. 2 Backlight doesn't light or color is wrong.	Major
		8. 3 Illumination source flickers when lit.	Major
09	General appearance	9. 1 Pin type must match type in specification sheet.	Major
		9. 2 No short circuits in components on PCB or FPC.	Major
		9. 3 Product packaging must the same as specified on packaging specification sheet.	Minor
		9. 4 The folding and peeled off in polarizer are not acceptable.	Minor
		9. 5 The PCB or FPC between B/L assembled distance (PCB or FPC) is ≤ 1.5 mm.	Minor

5. PRECAUTION RELATING PRODUCT HANDLING

5.1 SAFETY

- 5.1.1 If the LCD panel breaks , be careful not to get the liquid crystal to touch your skin.
- 5.1.2 If the liquid crystal touches your skin or clothes , please wash it off immediately by using soap and water.

5.2 HANDLING

- 5.2.1 Avoid any strong mechanical shock which can break the glass.
- 5.2.2 Avoid static electricity which can damage the CMOS LSI—When working with the module , be sure to ground your body and any electrical equipment you may be using.
- 5.2.3 Do not remove the panel or frame from the module.
- 5.2.4 The polarizing plate of the display is very fragile. So , please handle it very carefully ,do not touch , push or rub the exposed polarizing with anything harder than an HB pencil lead (glass , tweezers , etc.)
- 5.2.5 Do not wipe the polarizing plate with a dry cloth , as it may easily scratch the surface of plate.
- 5.2.6 Do not touch the display area with bare hands , this will stain the display area.
- 5.2.7 Do not use ketonics solvent & aromatic solvent. Use with a soft cloth soaked with a cleaning naphtha solvent.
- 5.2.8 To control temperature and time of soldering is $320\pm 10^{\circ}\text{C}$ and 3-5 sec.
- 5.2.9 To avoid liquid (include organic solvent) stained on LCM .

5.3 STORAGE

- 5.3.1 Store the panel or module in a dark place where the temperature is $25^{\circ}\text{C} \pm 5^{\circ}\text{C}$ and the humidity is below 65% RH.
- 5.3.2 Do not place the module near organics solvents or corrosive gases.
- 5.3.3 Do not crush , shake , or jolt the module.

5.4 TERMS OF WARRANTY

5.4.1 Applicable warrant period

The period is within thirteen months since the date of shipping out under normal using and storage conditions.

5.4.2 Unaccepted responsibility

This product has been manufactured to your company's specification as a part for use in your company's general electronic products. It is guaranteed to perform according to delivery specifications. For any other use apart from general electronic equipment , we cannot take responsibility if the product is used in nuclear power control equipment , aerospace equipment , fire and security systems or any other applications in which there is a direct risk to human life and where extremely high levels of reliability are required.

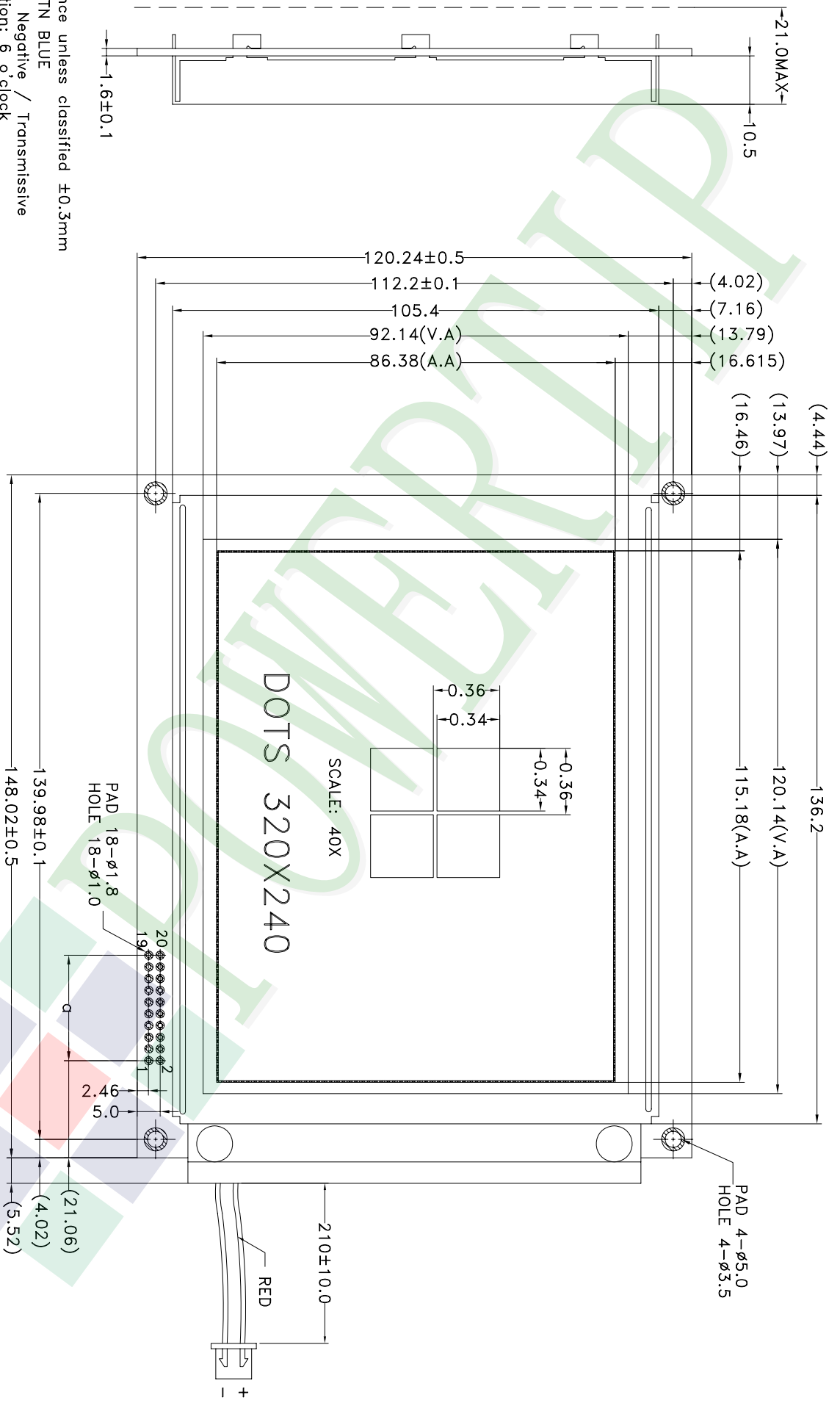

- NOTES:
- 1.The tolerance unless classified $\pm 0.3\text{mm}$
 - 2.LCD type:STN BLUE
 - 3.LCD mode: Negative / Transmissive
 - 4.View direction: 6 o'clock
 5. $T_{op} = -20^{\circ}\text{C} \sim 70^{\circ}\text{C}$, $T_{st} = -30^{\circ}\text{C} \sim 80^{\circ}\text{C}$
 - 6.a:P2.54x9=22.86±0.1

007																							
006																							
005																							
004																							
003																							
002																							
001	NEW DRAWING																						
REV		REV BY	Sally	REVISER	DATE	2013/06/26																	
		PART NO.:	PG320240WRMDBA130Q																				
		DRAWING NAME:	JLMD-PG320240WRMDBA130Q																				
		TITLE:	LCD Module Drawing																				
		Design	Sally																				
		Check	Terry																				
		Approve	Ryan																				
		Unit	MM																				
		Scale	1:1																				
		Page	1/1																				
		Surface																					
		Material																					
		Thickness																					
		Quantity																					
		公差標準	1 ~ 4																				
		精度	4 ~ 16																				
			16 ~ 63																				
			63 ~ 250																				
			250 ~ 1000																				

Ver.001

Documents NO. JPKG-PG320240WRMDBAI30Q

LCM包裝規格書

LCM Packaging Specifications

Approve	Check	Contact
Ryan	Terry	Sally

1. 包裝材料規格表 (Packaging Material) : (per carton)

No.	Item	Model	Dimensions (mm)	1Pcs Weight	Quantity	Total Weight
1	成品 (LCM)	PG320240WRMDBAI30Q	148.02 X 120.24	0.26	36	9.36
2	氣泡袋(1)Bubble Bag	BAG170150BRABA	170 X 150	0.0045	36	0.162
3	A6隔板(2)A6 Partition	BX33800012BZBA	338 X 125 X 3	0.0148	22	0.3256
4	B6隔板(3)B6 Partition	BX00000000056	298 X 125 X 3	0.023	6	0.1362
5	海綿墊(4)Foam Rubber Cushion	OTFOAM00005ABA	330 X 290 X 10	0.025	4	0.1
6	C4內盒(5)Product Box	BX36031014AABA	360 X 310 X 142	0.324	2	0.648
7	外紙箱(6)Carton	BX39432432CCBA	394 X 324 X 321	0.65	1	0.65
8						
9						

2. 一 整箱總重量 (Total LCD Weight in carton) : 11.4 Kg±10%

3. 單箱數量規格表 (Packaging Specifications and Quantity) :

(1)Quantity Of Spacer : A6隔板 X 11 , B6隔板 X 3
 (2)Total LCM quantity in carton : quantity per box 18 x no of boxes 2 = 36

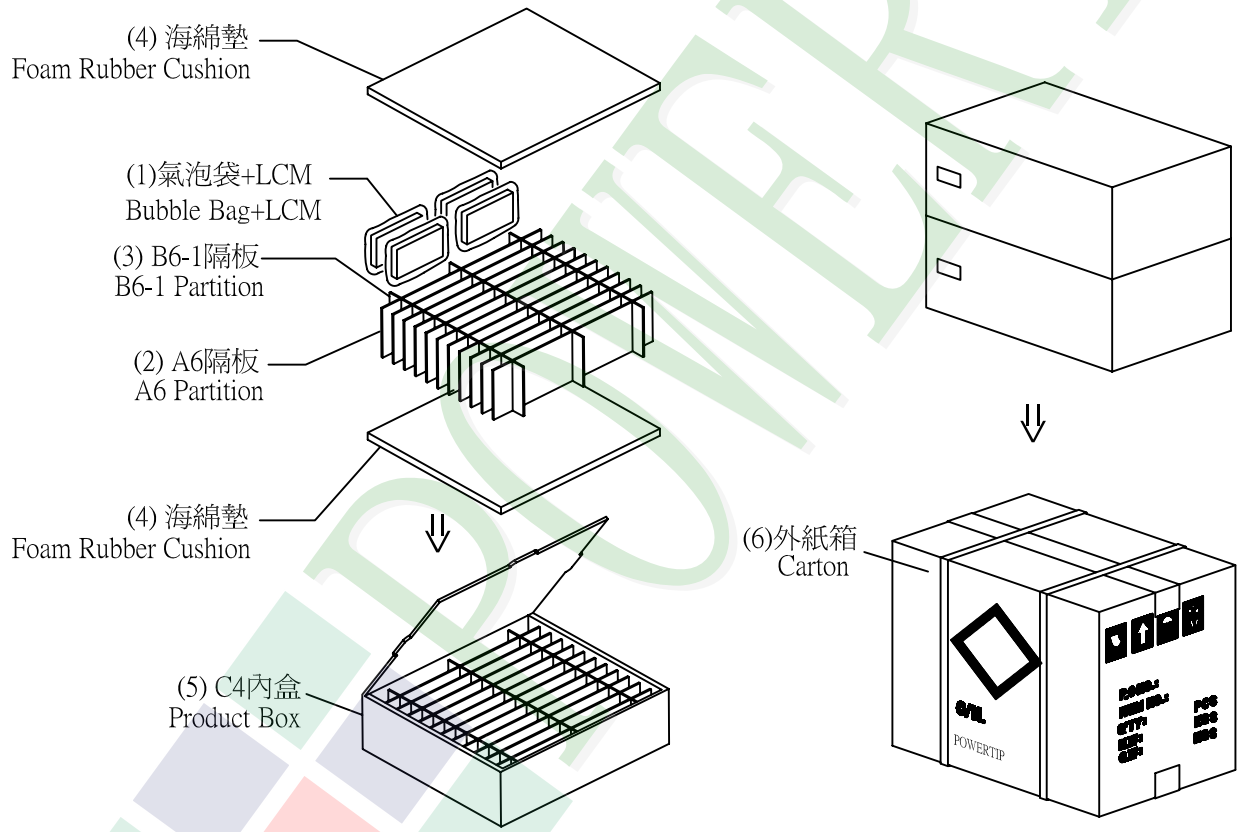

特 記 事 項 (REMARK)

4. Label Specifications :
標籤依廠內標準作業

5. LCM排放示意圖(前、中、後間隔不放置):
5. LCM placed as figure showing:
(First middle and last slot should be empty)

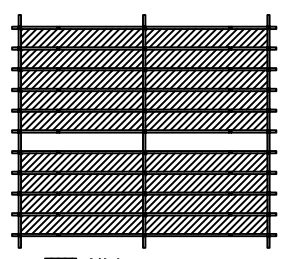

■ 模組(LCM) X 1pcs.