

REV.	DESCRIPTION	DRAWN	CHECKED	APPROVED
A	NEW RELEASE	YCH 11/03/09'	~	

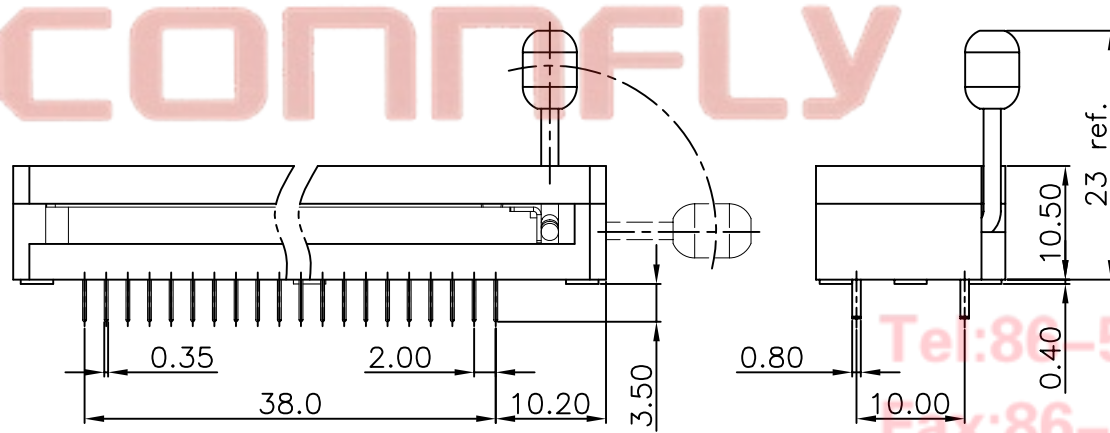
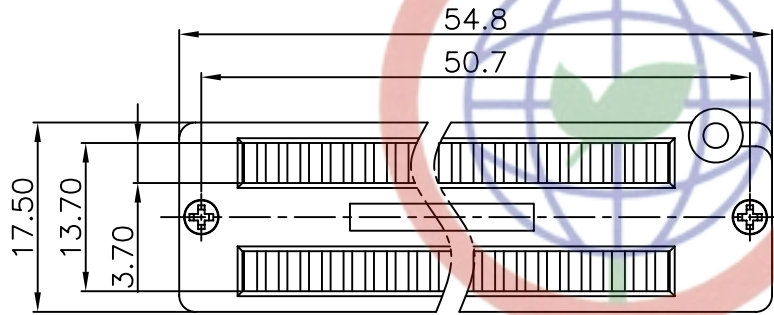

N=No. of contacts/2

1. FEATURES

- 1.1. Compact mechanical construction to ensure long term life.
- 1.2. Zero insertion and extraction pressure.
- 1.3. standard 0.079(2.00mm) IC pitch, easy to mount in PC board.
- 1.4. All plastics are UL 94v-0 grade fire retardant.
- 1.5. Gold plated contact to ensure low contact resistance and long operation life.

2. SPECIFICATION

2.1. ELECTRICAL:

- 2.1.1. Rating: 50VDC, 100mA.
- 2.1.2. Contact Resistance: 50mΩ Max.
- 2.1.3. Insulation Resistance: 1000MΩ Min.
- 2.1.4. Dielectric withstanding volatage: 500VDC min. for 60 seconds. Capacitance between adjacent contacts.

2.2. MECHANICAL AND ENVIRONMENTAL

- 2.2.1. Temperature Rating:
- 2.2.2. Operating: -25°C to +70°C
- 2.2.3. Storage: -40°C to +85°C
- 2.2.4. Durability: 25,000 cycles (with load)
- 2.2.5. Humidity: 95%RH, 40°C for 48 Hrs.
- 2.2.6. Solderability: After flux 230°C for 5±0.5 Seconds, 95% coverage
- 2.2.7. Soldering Heat: 260±5°C for 5±1 Seconds.

3. PRODUCT NUMBER CODE:

DS1043-01 - X X X

Housing color

- L: Blue
- B: Black
- G: Green

Contact plating

- 6: Full Tin
- F: Full 3u" gold
- 0: Full gold flash

No. of contacts

- 10 16 20
- 26 34 40

GENERAL TOLERANCE		ANGLE TOLERANCE		PROJECTION	TITLE
X.	±0.60	X.	±5°		ZIF SOCKET
.X	±0.38	.X	±3°	mm	
.XX	±0.25	.XX	±2°	A4	SERIES DS1043-01 SERIES
DRAWING TYPE		CUSTOMER		晨翔电子有限公司 CONNFLY CONNFLY ELECTRONIC CO. LTD	
SCALE		1:1	SHEET 1 OF 1		
DRAWING NO.		C-DS1043-01-XXX			