

L293D Stepper Motor Driver

FEATURES

- L293D Stepper Motor Driver Module
- Input Voltage: DC 4.5V to 25V
- Output Peak Current: 1.2A / Channel
- Output Current: 600mA / Channel

APPLICATIONS

- DC Motor Drivers
- Stepper Motor Drivers

DESCRIPTION

The L293D Module is quadruple high-current half-H drivers. The Module is designed to provide bidirectional drive currents of up to 600mA at voltages from 4.5V to 36V

APPLICATION GUIDE

The Module is designed to drive inductive loads such as relays, solenoids, DC and bipolar stepping motors, as well as other high-current/high-voltage loads in positive supply applications. Each output is a complete totem-pole drive circuit, with a Darlington transistor sink and a pseudo-Darlington source. Drivers are enabled in pairs, with drivers 1 and 2 enabled by EN1/2 and drivers 3 and 4 enabled by EN3/4.

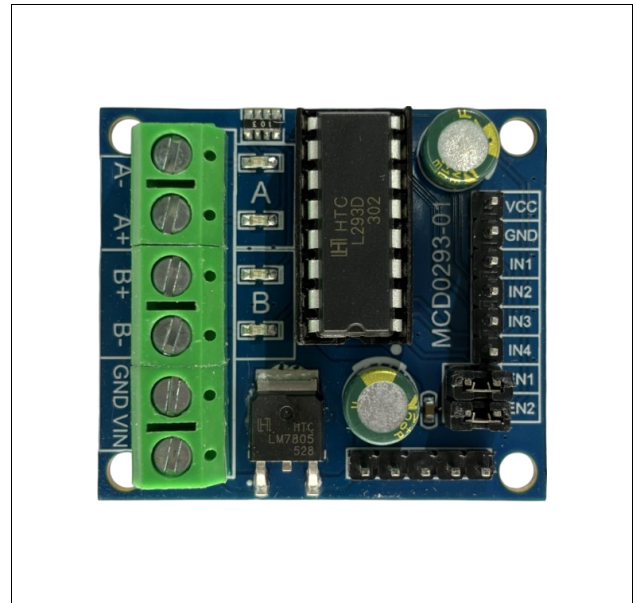

ORDERING INFORMATION

Part Number	MCD0293-01
Device	L293D Stepper Motor Driver
Package	Assembled Module (35mm X 40mm)

L293D Stepper Motor Driver

SCHEMATICS

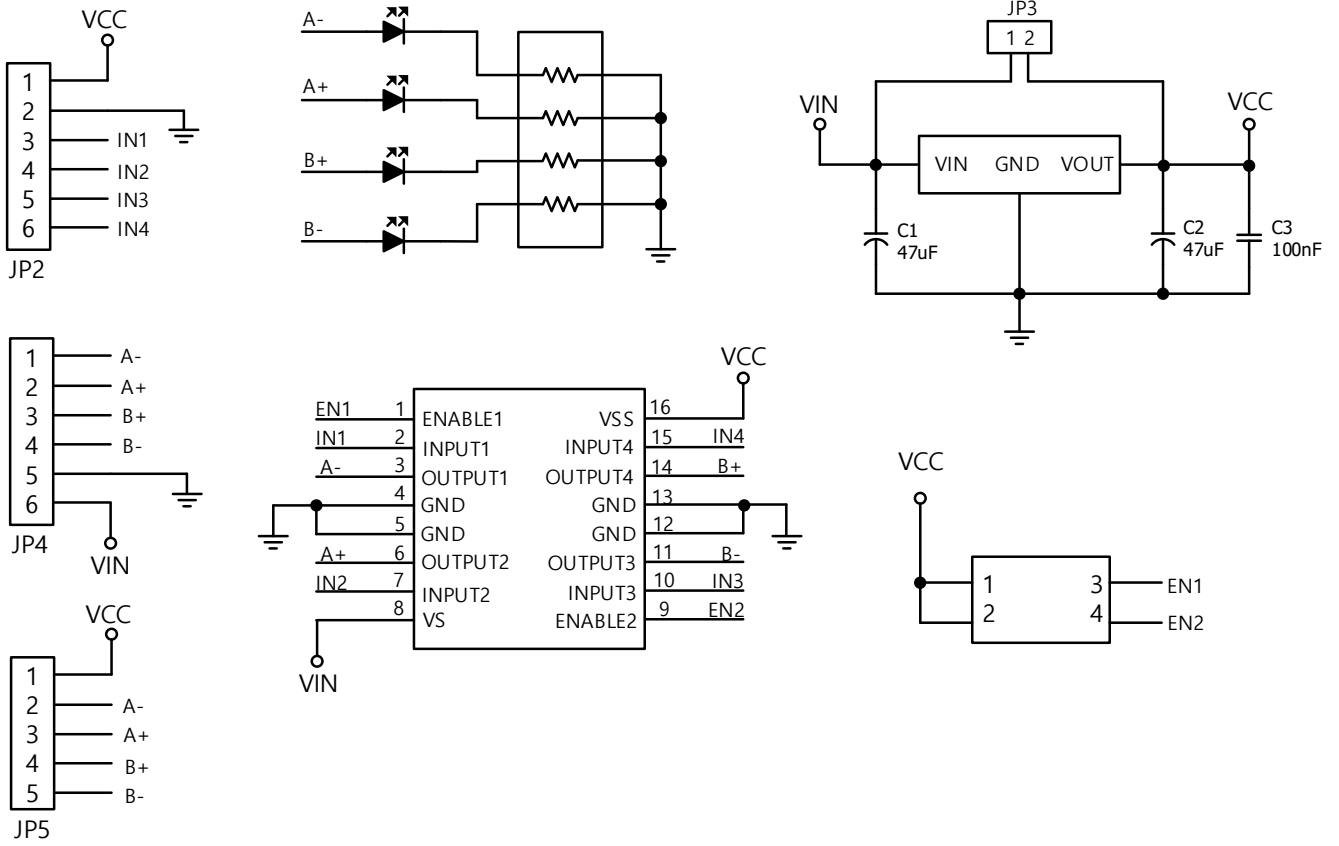

LAYOUT

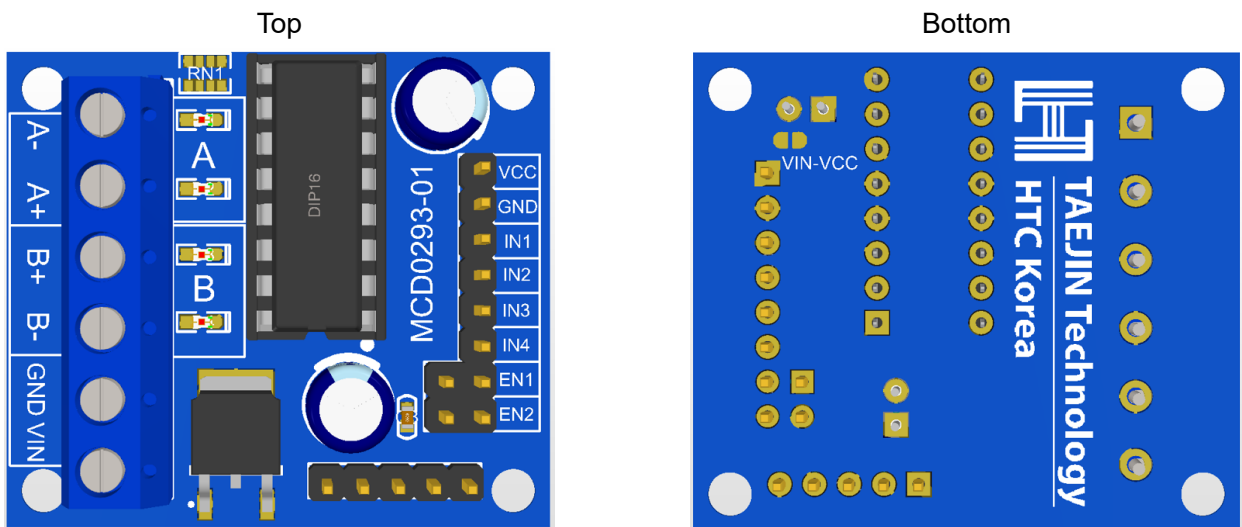

L293D Stepper Motor Driver

PARTS LIST

Name	Description	P/N	Qty.	Distributor
PCB	Printed Circuit Board	FR4 Lead-Free PCB	1	TAEJIN
IC	L293D, DIP-16	L293DN	1	TAEJIN
IC	LM7805, TO-252-3L	LM7805RS	1	TAEJIN
Connector	Wire to Board Connector	KF301	3	Generic
Pin Header	1*5 / 2.54mm pitch	Male Pin Header	1	Generic
Pin Header	1*6 / 2.54mm pitch	Male Pin Header	1	Generic
Pin Header	2*2 / 2.54mm pitch	Male Pin Header	1	Generic
Resistor	10KΩ * 4 Array Resistor	10KΩ 5% * 4 Array Resistor	4	Generic
LED	LED for Indicator	LED, Green	4	Generic
Jumper	2pin 2.54mm pitch	Jumper Cap	2	Generic
Capacitor	100nF / 50V Capacitor	100nF / 50V Capacitor 1608(0603)	1	Generic
Capacitor	47μF Capacitor	470μF/50V Electrolytic Capacitor	2	Generic

SIZE INFORMATION

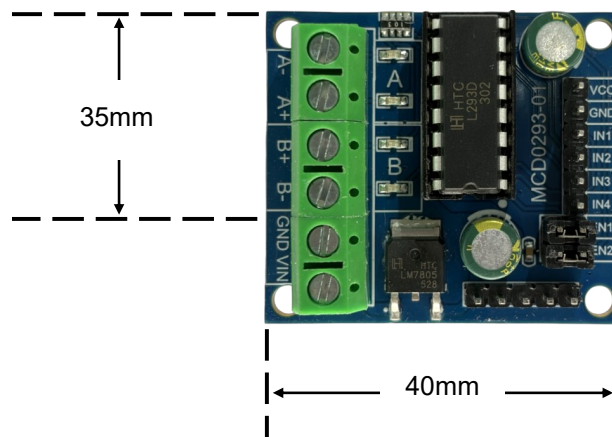

L293D Stepper Motor Driver

PRODUCT IMAGE

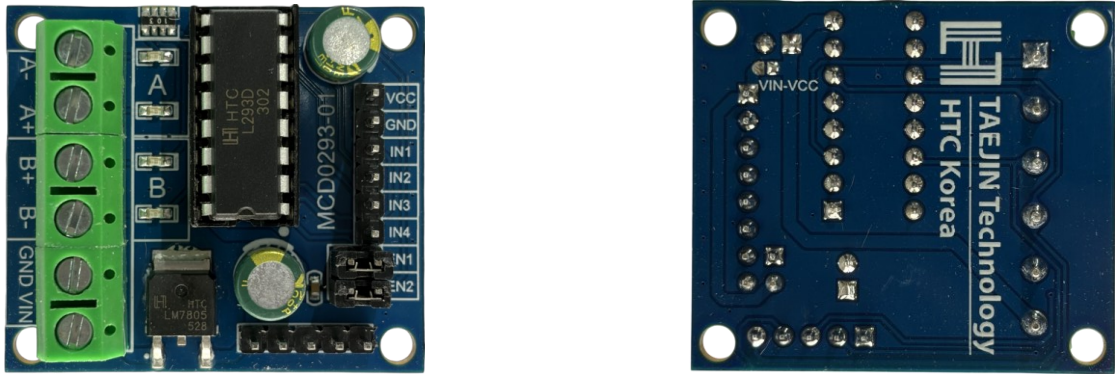

I/O PORT CONFIGURATION AND DESCRIPTION

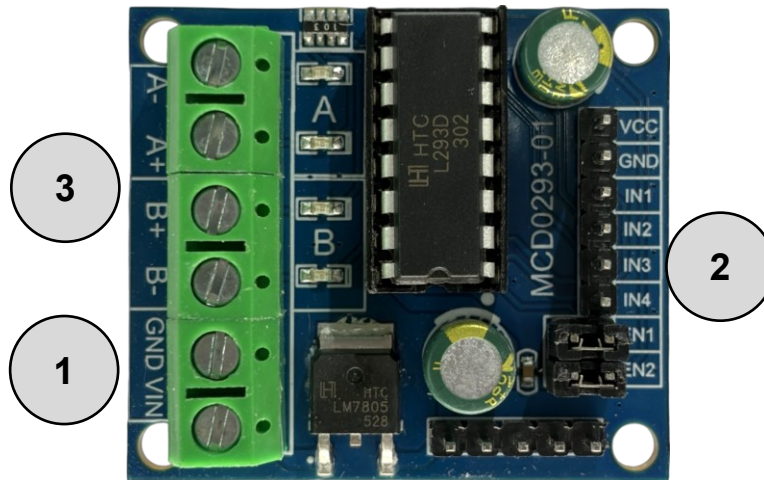

Designator	Port Name	Port Description
1	Input Supply Port	Input Voltage Range : DC 4.5V to 25V
2	Driver Input Port	Motor Driver Input
3	Driver Output Port	Motor Driver Output

L293D Stepper Motor Driver

REVISION NOTICE

The description in this datasheet is subject to change without any notice to describe its electrical characteristics properly.

FEATURES

- Wide Supply-Voltage Range: 4.5V to 36V
- Separate Input-Logic Supply
- Internal ESD Protection (HBM 2kV)
- High-Noise-Immunity Inputs
- Output Current 600mA Per Channel
- Peak Output Current 1.2A Per Channel
- Output Clamp Diodes for Inductive Transient Suppression

APPLICATION

- Stepper Motor Drivers
- DC Motor Drivers
- Latching Relay Drivers

DESCRIPTION

The L293D device is quadruple high-current half-H drivers. The L293D is designed to provide bidirectional drive currents of up to 600mA at voltages from 4.5V to 36V. The device is designed to driver inductive loads such as relays, solenoids, DC and bipolar stepping motors, as well as other high-current/high-voltage loads in positive-supply applications.

Each output is a complete totem-pole drive circuit, with a Darlington transistor sink and a pseudo-Darlington source. Drivers are enabled in pairs, with drivers 1 and 2 enabled by EN1/2 and drivers 3 and 4 enabled by EN3/4. The L293D is characterized for operation from 0°C to 70°C.

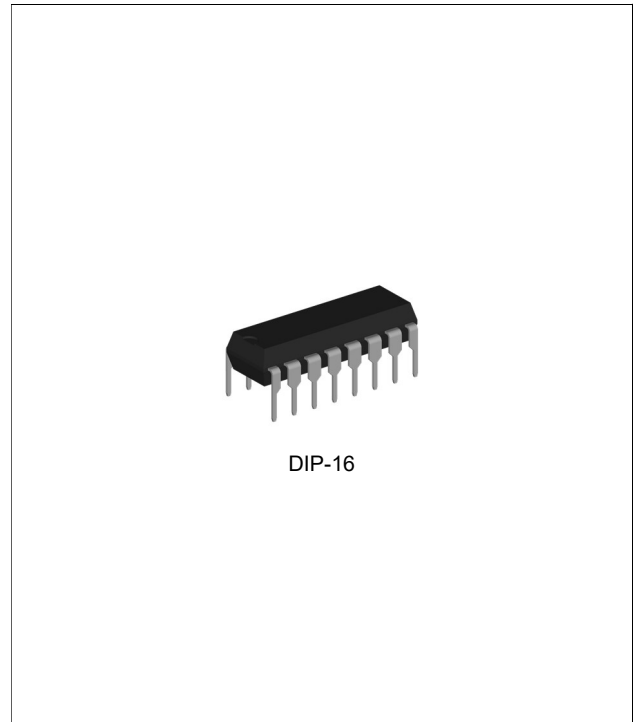

ORDERING INFORMATION

Device	Package
L293DN	DIP-16

ABSOLUTE MAXIMUM RATINGS (Note 1)

CHARACTERISTIC	SYMBOL	MIN	MAX	UNIT
Logic Supply Voltage <small>(Note 2)</small>	V _{CC1}	-0.3	36	V
Power Supply Voltage	V _{CC2}	-0.3	36	V
Input Voltage	V _{IN}	-0.3	7.0	V
Enable Input Voltage	V _{EN}	-0.3	7.0	V
Output Voltage	V _{OUT}	-3.0	V _{CC2} + 3.0	V
Peak Output Current (non-repetitive, t ≤ 100 μs)	I _{OUT,PEAK}	-1.2	1.2	A
Continuous Output Current	I _{OUT,CONT}	-600	600	mA
Maximum Junction Temperature Range	T _J	-	150	°C
Storage Temperature Range	T _{STG}	-65	150	°C

Note 1. Stresses beyond those listed under Absolute Maximum Ratings may cause permanent damage to the device. These are stress rating only which do not imply functional operation of the device at these or any other conditions beyond those indicated under Recommended Operating conditions. Exposure to absolute maximum rated conditions for extended periods may affect device reliability.

Note 2. All voltage values are with respect to the network ground terminal.

RECOMMENDED OPERATING CONDITIONS

CHARACTERISTIC	SYMBOL	MIN	MAX	UNIT
Logic Supply Voltage	V _{CC1}	4.5	7.0	V
Power Supply Voltage	V _{CC2}	V _{CC1}	36	V
High Level Input Voltage (V _{CC1} ≤ 7.0 V)	V _{IH}	2.3	V _{CC1}	V
High Level Input Voltage (V _{CC1} > 7.0 V)	V _{IH}	2.3	7.0	V
Low Level Input Voltage	V _{IL}	-0.3 <small>(Note 3)</small>	1.5	V
Operating Free-Air Temperature Range	T _A	0	70	°C

Note 3. The algebraic convention, in which the least positive (most negative) designated minimum, is used in this datasheet for logic voltage levels.

ORDERING INFORMATION

Package	Order No.	Description	Supplied As	Status
DIP-16	L293DN	Quadruple Half-H Drivers	Tube	Active

PIN CONFIGURATION

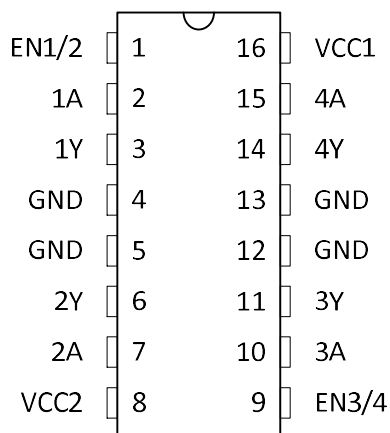

DIP-16

PIN DESCRIPTION

Pin No.	Pin Name	Pin Function
1	EN1/2	Enable Driver Channels 1 and 2. Active High Input.
2	1A	Driver 1 Input. Non-Inverting.
3	1Y	Driver 1 Output.
4, 5, 12, 13	GND	Device Ground and Heat Sink pin. Connect to PCB ground plane with multiple solid vias.
6	2Y	Driver 2 Output.
7	2A	Driver 2 Input. Non-Inverting.
8	VCC2	Power VCC for Drivers 4.5V to 36V.
9	EN3/4	Enable Driver Channels 3 and 4. Active High Input.
10	3A	Driver 3 Input. Non-Inverting.
11	3Y	Driver 3 Output.
14	4Y	Driver 4 Output.
15	4A	Driver 4 input. Non-Inverting.
16	VCC1	5V Supply for Internal Logic Translation.

DC ELECTRICAL CHARACTERISTICS

T_A = 25°C, unless otherwise noted.

PARAMETER	SYMBOL	TEST CONDITIONS	MIN	TYP	MAX	UNIT
High Level Output Voltage	V _{OH}	I _{OH} = -0.6 A	V _{CC2} - 1.8	V _{CC2} - 1.4	-	V
Low Level Output Voltage	V _{OL}	I _{OL} = 0.6 A	-	1.2	1.8	V
High Level Output Clamp Voltage	V _{OKH}	I _{OK} = -0.6 A	-	V _{CC2} + 1.3	-	V
Low Level Output Clamp Voltage	V _{OKL}	I _{OK} = 0.6 A	-	1.3	-	V
Input Voltage High Level	V _{IH}		2.3	-	-	V
Input Voltage Low Level	V _{IL}		-	-	1.5	V
Enable Voltage High Level	V _{ENH}		2.3	-	-	V
Enable Voltage Low Level	V _{ENL}		-	-	1.5	V
Input Current High Level	I _{IH}	V _{IN} = 7.0 V	-	0.2	100	μA
Input Current Low Level	I _{IL}	V _{IN} = 0 V	-	-3.0	-10	μA
Enable Current High Level	I _{ENH}	V _{IN} = 7.0 V	-	0.2	10	μA
Enable Current Low Level	I _{ENL}	V _{IN} = 0 V	-	-2.0	-100	μA
Logic Supply Current	I _{CC1}	I _{OUT} = 0 A, All Outputs at High Level	-	13	26	mA
		I _{OUT} = 0 A, All Outputs at Low Level	-	35	60	
		I _{OUT} = 0 A, All Outputs at High Impedance	-	8.0	24	
Power Supply Current	I _{CC2}	I _{OUT} = 0 A, All Outputs at High Level	-	14	24	mA
		I _{OUT} = 0 A, All Outputs at Low Level	-	2.0	6.0	
		I _{OUT} = 0 A, All Outputs at High Impedance	-	2.0	4.0	

AC ELECTRICAL CHARACTERISTICS

T_A = 25°C, V_{CC1} = 5.0 V, V_{CC2} = 24 V, unless otherwise noted.

PARAMETER	SYMBOL	TEST CONDITIONS	MIN	TYP	MAX	UNIT
Turn-On Delay from Input to Output	t _{PLH}	C _L = 30 pF	-	800	-	ns
Turn-Off Delay from Input to Output	t _{PHL}	C _L = 30 pF	-	400	-	ns
Transition Time, Output Low to High	t _{TLH}	C _L = 30 pF	-	300	-	ns
Transition Time, Output High to Low	t _{THL}	C _L = 30 pF	-	300	-	ns

PARAMETER MEASUREMENT INFORMATION

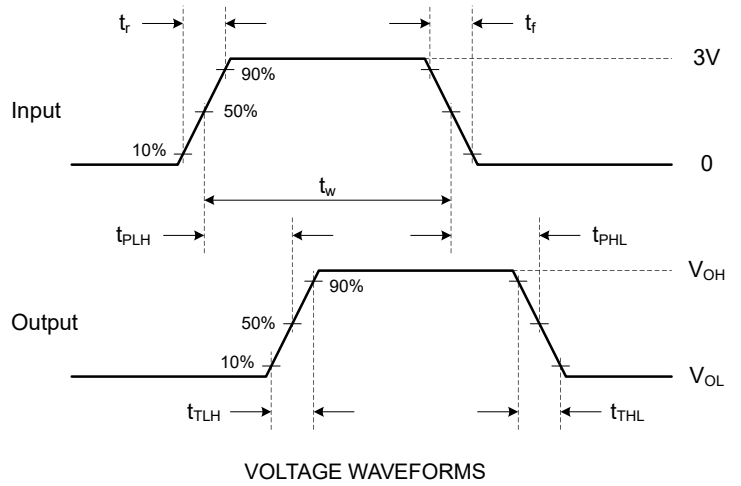
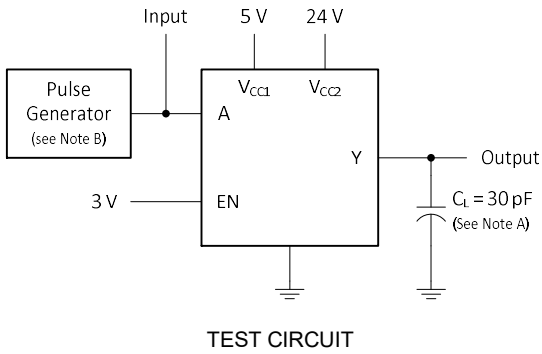

Note A. C_L includes probe and jig capacitance.

Note B. The pulse generator has the following characteristics: $t_r \leq 10$ ns, $t_f \leq 10$ ns, $t_w = 10$ μ s, PRR = 5 kHz, $Z_o = 50$ Ω .

Test Circuit and Voltage Waveforms

FUNCTION TABLE

Input (A)	Input (EN)	Output (Y)
H	H	H
L	H	L
X	L	Z

APPLICATION INFORMATION

OVERVIEW

The L293D is quadruple high-current half-H driver. This device is designed to drive a wide array of inductive loads such as relays, solenoids, DC and bipolar stepping motors, as well as other high current and high voltage loads. All inputs are TTL compatible and tolerant up to 7.0 V.

Each output is a complete totem-pole drive circuit, with a Darlington transistor sink and a pseudo-Darlington source. Drivers are enabled in pairs, with drivers 1 and 2 enabled by EN1/2 and drivers 3 and 4 enabled by EN3/4. When an enable input is high, the associated drivers are enabled, and their outputs are active and inphase with their inputs. When the enable input is low, those drivers are disabled, and their outputs are off and in the high-impedance state. With the proper data inputs, each pair of drivers forms a full-H (or bridge) reversible drive suitable for solenoid or motor applications.

On the L293D, output clamp diodes are integrated to reduce system complexity and overall system size. A VCC1 terminal, separate from VCC2, is provided for the logic inputs to minimize device power dissipation. The L293D is characterized for operation from 0 °C to 70 °C.

The L293D has TTL compatible inputs and high voltage outputs for inductive load switching. Current outputs can get up to 1.2A using L293D.

POWER SUPPLY RECOMMENDATIONS

VCC1 is 5.0 V \pm 0.5 V and VCC2 can be same supply as VCC1 or a higher voltage supply with peak voltage up to 36 V. Bypass capacitors of 0.1 μ F or greater should be used at VCC1 and VCC2 pins. There are no power-up or power-down supply sequence order requirements.

Properly heatsinking the L293D when driving high-current is critical to design. The θ_{JA} of the L293D can be reduced by soldering the GND to a suitable copper area of the PCB or to an external heat sink.

The external heatsink or copper area must be connected to electrical ground.

LAYOUT GUIDELINES

Place the device near the load to keep output traces to reduce EMI. Use solid vias to transfer heat from ground pins to ground plane of the PCB.

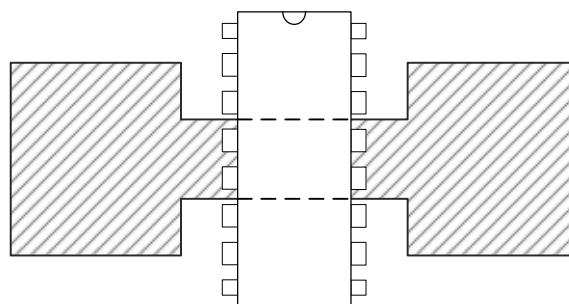

Layout Example of PCB Copper Area (Used as Heat Sink)

REVISION NOTICE

The description in this datasheet is subject to change without any notice to describe its electrical characteristics properly.