

# LM2596 Buck Converter Module

## FEATURES

- LM2596 DC-DC Buck Converter Step Down Module
- Input Voltage Range: 7V to 35V
- Output Voltage: 5V (USB Output)
- Output Current: Max. 1.0A (CH1) / Max. 2.0A (CH2)
- Switching Frequency: 150kHz

## APPLICATIONS

- Simple high efficiency step-down regulator
- On-card switching regulator
- DIY USB fast charger for smart phones, and tablet

## DESCRIPTION

The LM2596 Buck Converter Module is a non-isolated step-down DC-DC converter with non-synchronous rectification.

## APPLICATION GUIDE

The power dissipation of the LM2596 Buck Converter Module is internally limited. Small sized PCB and thermal resistance of IC package have limited the power dissipation of the module.

Depending on the conversion condition, 3A full loading is not might possible due to the internally limited power dissipation.

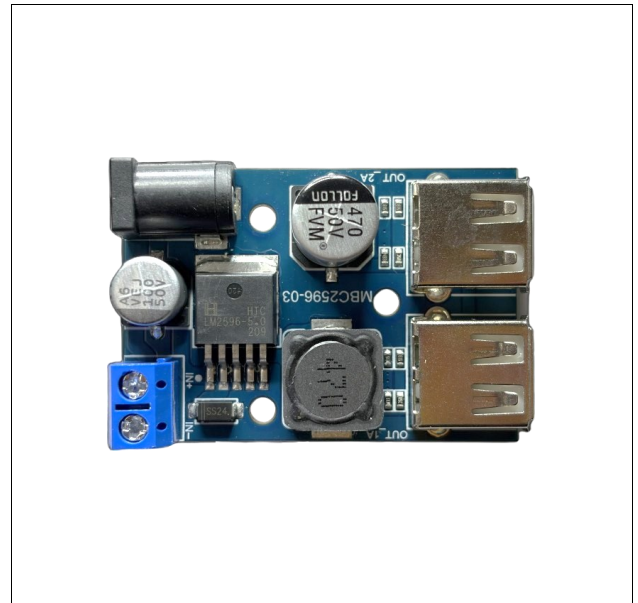

## ORDERING INFORMATION

Part Number	MBC2596-03
Device	LM2596 Buck Converter Module
Package	Assembled Module (50mm X 35mm)

# LM2596 Buck Converter Module

## SCHEMATICS

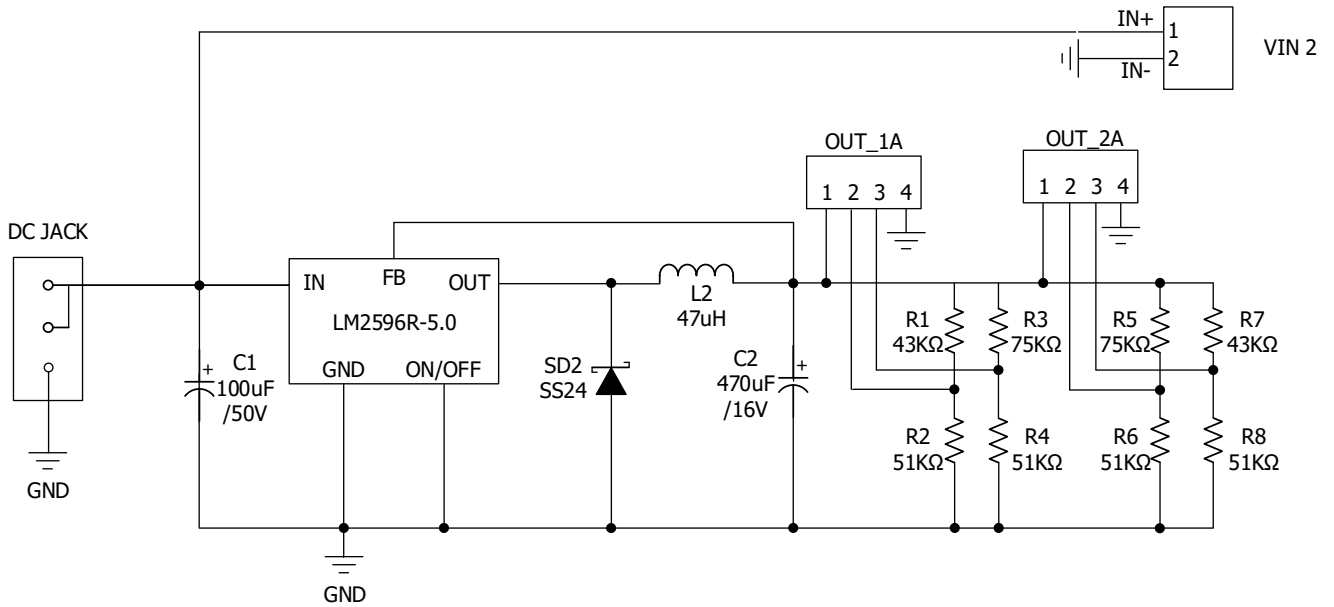

## LAYOUT

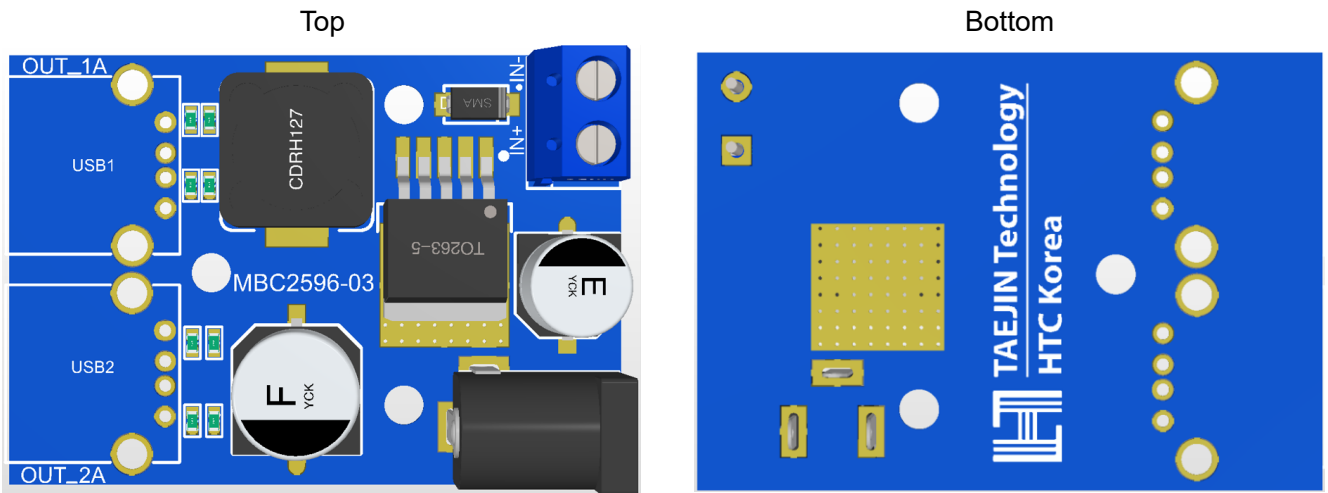

# LM2596 Buck Converter Module

## PARTS LIST

Name	Description	P/N	Qty.	Distributor
PCB	Printed Circuit Board	FR4 Lead-Free PCB	1	TAEJIN
IC	LM2596-5.0, TO-263-5L	LM2596R-5.0	1	TAEJIN
Connector	Wire to Board Connector	KF301	1	Generic
Connector	USB A-Type	USB Jack	2	Generic
Jack	DC-005-2.1	DC Jack	1	Generic
Diode	Schottky Power Rectifier Diodes	SS24	1	Generic
Inductor	47 $\mu$ H Inductor	47 $\mu$ H Inductor SMD	2	Generic
Resistor	75K $\Omega$ Resistor	75K $\Omega$ 1% Resistor, 1608(0603)	2	Generic
Resistor	51K $\Omega$ Resistor	51K $\Omega$ 5% Resistor, 1608(0603)	4	Generic
Resistor	43K $\Omega$ Resistor	43K $\Omega$ 5% Resistor, 1608(0603)	2	Generic
Capacitor	100 $\mu$ F Capacitor	100 $\mu$ F/50V Electrolytic Capacitor	1	Generic
Capacitor	470 $\mu$ F Capacitor	470 $\mu$ F/50V Electrolytic Capacitor	1	Generic

## SIZE INFORMATION

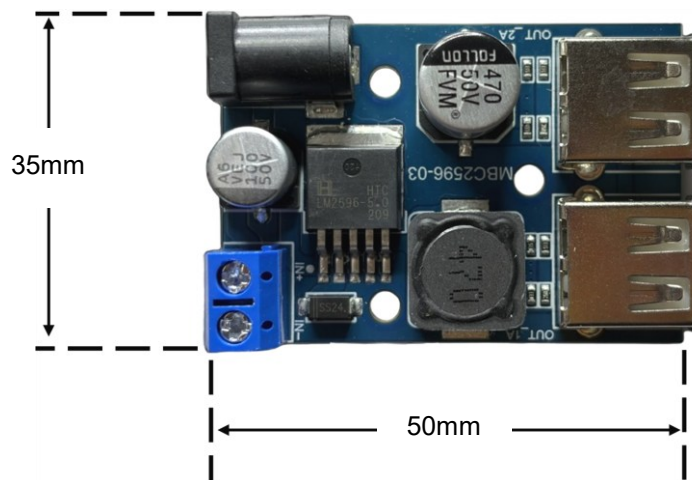

# LM2596 Buck Converter Module

## PRODUCT IMAGE

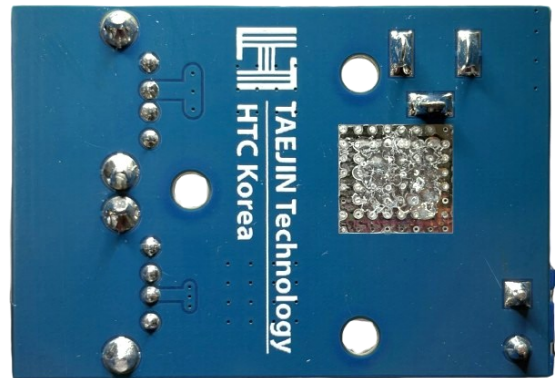
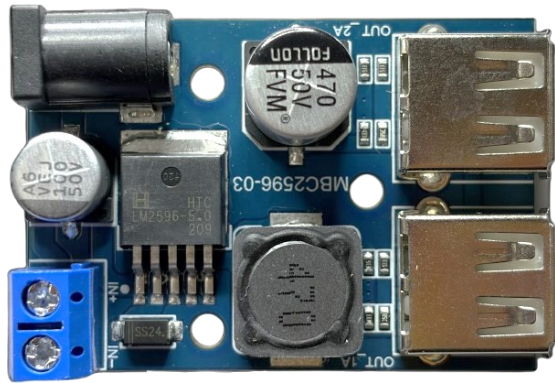

## I/O PORT CONFIGURATION AND DESCRIPTION

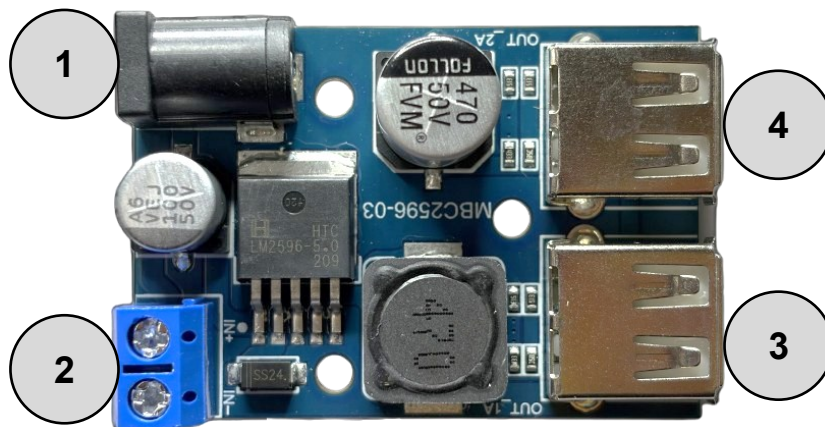

Designator	Port Name	Port Description
1	Input Connector 1	Input DC 7V to 35V
2	Input Connector 2	Input DC 7V to 35V
3	Output Connector 1	USB Output 1 (Ch1)
4	Output Connector 2	USB Output 2 (Ch2)

# LM2596 Buck Converter Module

---

## REVISION NOTICE

The description in this datasheet is subject to change without any notice to describe its electrical characteristics properly.

## FEATURES

- 3.3V, 5.0V, 12V, and Adjustable Output version
- Adjustable Output Voltage range, 1.2V to 37V  
±4% Max. Over Line and Load conditions
- Guaranteed Output Current of 3A
- Available in TO-263, TO-220, SOP-8PP Packages
- Requires Only 4 External Components
- Excellent Line and Load Regulation Specifications
- 150kHz Fixed Frequency Internal Oscillator
- TTL Shutdown Capability
- Low Power Standby Mode, IQ typically 100mA
- Thermal Shutdown and Current Limit Protection
- Moisture Sensitivity Level 3

## APPLICATION

- Simple High-Efficiency Step-Down(Buck) Regulator
- Efficient Pre-Regulator for Linear Regulators
- On-Card Switching Regulators
- Positive to Negative Converter(Buck-Boost)
- Negative Step-Up Converters
- Power Supply for Battery Chargers

## DESCRIPTION

The LM2596 series of regulators are monolithic integrated circuits ideally suited for easy and convenient design of a step-down switching regulator (buck converter). All circuits of this series are capable of driving a 3.0A load with excellent line and load regulation. These devices are available in fixed output voltages of 3.3V, 5.0V, 12V, and an adjustable output version. These regulators were designed to minimize the number of external components to simplify the power supply design. Standard series of inductors optimized for use with the LM2596 are offered by several different inductor manufacturers. Since the LM2596 converter is a switch-mode power supply, its efficiency is significantly higher in comparison with popular three-terminal linear regulators, especially with higher input voltages. In many cases, the power dissipated is so low that no heatsink is required or its size could be reduced dramatically. A standard series of inductors optimized for use with the LM2596 are available from several different manufacturers. This feature greatly simplifies the design of switch-mode power supplies. The LM2596 features include a guaranteed +/- 4% tolerance on output voltage within specified input voltages and output load conditions, and +/-15% on the oscillator frequency (+/- 2% over 0°C to 125°C). External shutdown is included, featuring 80µA (typical) standby current. Self-protection features include a two stage frequency reducing current limit for output switch and an over temperature shutdown for complete protection under fault conditions.

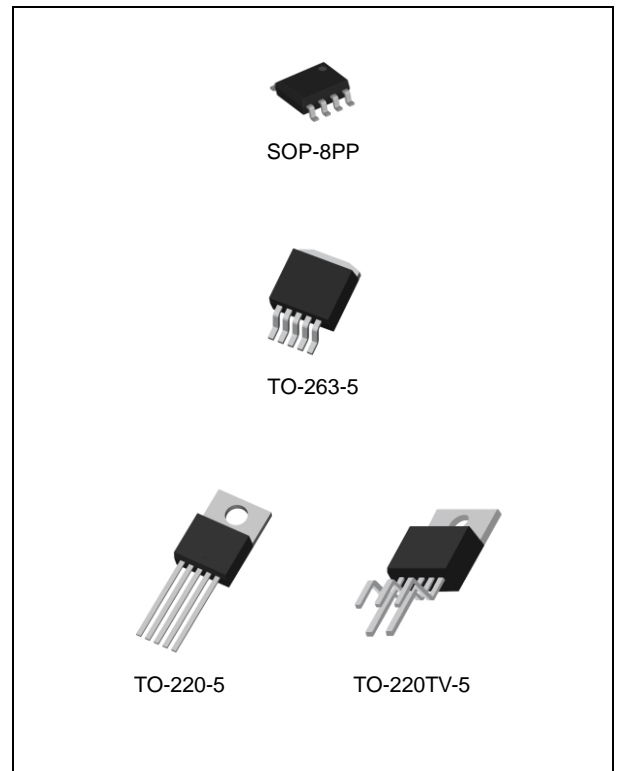

## ORDERING INFORMATION

Device	Package
LM2596R-X.X	TO-263-5L
LM2596T-X.X	TO-220-5L
LM2596TV-X.X	TO-220TV-5L
LM2596DP-X.X	SOP-8PP

X.X = Output Voltage = 3.3, 5.0, 12, ADJ

## 3.0A, 150kHz, Step-Down Switching Regulator

LM2596

### Ordering Information

V <sub>OUT</sub>	Package	Order No.	Description	Package Marking	Status
ADJ	SOP-8PP	LM2596DP-ADJ	3A, Adjustable, 150kHz, On/off	LM2596-ADJ	Active
	TO-220-5L	LM2596T-ADJ	3A, Adjustable, 150kHz, On/off	LM2596-ADJ	Active
	TO-220TV-5L	LM2596TV-ADJ	3A, Adjustable, 150kHz, On/off	LM2596-ADJ	Active
	TO-263-5L	LM2596R-ADJ	3A, Adjustable, 150kHz, On/off	LM2596-ADJ	Active
3.3V	SOP-8PP	LM2596DP-3.3	3A, Fixed, 150kHz, On/off	LM2596-3.3	Active
	TO-220-5L	LM2596T-3.3	3A, Fixed, 150kHz, On/off	LM2596-3.3	Active
	TO-263-5L	LM2596R-3.3	3A, Fixed, 150kHz, On/off	LM2596-3.3	Active
5.0V	SOP-8PP	LM2596DP-5.0	3A, Fixed, 150kHz, On/off	LM2596-5.0	Active
	TO-220-5L	LM2596T-5.0	3A, Fixed, 150kHz, On/off	LM2596-5.0	Active
	TO-220TV-5L	LM2596TV-5.0	3A, Fixed, 150kHz, On/off	LM2596-5.0	Active
	TO-263-5L	LM2596R-5.0	3A, Fixed, 150kHz, On/off	LM2596-5.0	Active
12V	SOP-8PP	LM2596DP-12	3A, Fixed, 150kHz, On/off	LM2596-12	Contact Us
	TO-220-5L	LM2596T-12	3A, Fixed, 150kHz, On/off	LM2596-12	Active
	TO-220TV-5L	LM2596TV-12	3A, Fixed, 150kHz, On/off	LM2596-12	Active
	TO-263-5L	LM2596R-12	3A, Fixed, 150kHz, On/off	LM2596-12	Active

## PIN CONFIGURATION

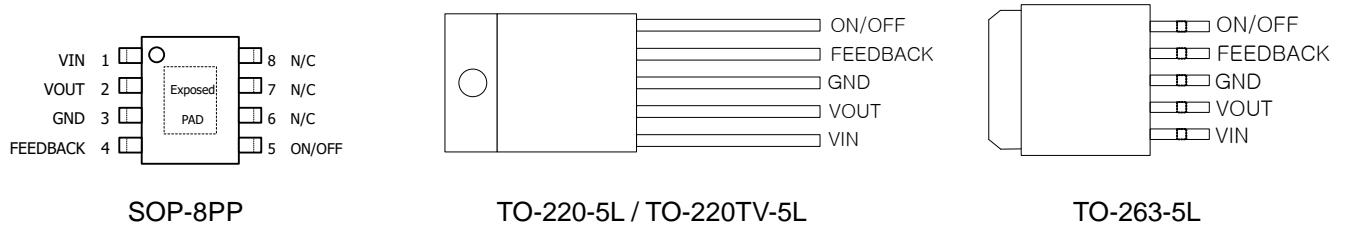

## PIN DESCRIPTION

Package		Symbol	Description
TO-220-5 TO-220TV-5 TO-263-5	SOP-8PP		
1	1	VIN	This pin is the positive input supply for the LM2596 step-down switching regulator. In order to minimize voltage transients and to supply the switching currents needed by the regulator, a suitable input bypass capacitor must be present.
2	2	VOUT	This is the emitter of the internal switch. The saturation voltage $V_{sat}$ of this output switch is typically 1.5 V. It should be kept in mind that the PCB area connected to this pin should be kept to a minimum in order to minimize coupling to sensitive circuitry.
3	3	GND	Circuit ground pin.
4	4	FEEDBACK	This pin senses regulated output voltage to complete the feedback loop. The signal is divided by the internal resistor divider network R2, R1 and applied to the non-inverting input of the internal error amplifier. In the Adjustable version of the LM2596 switching regulator this pin is the direct input of the error amplifier and the resistor network R2, R1 is connected externally to allow programming of the output voltage.
5	5	ON/OFF	It allows the switching regulator circuit to be shut down using logic level signals, thus dropping the total input supply current to approximately 80uA. The threshold voltage is typically 1.3V. Applying a voltage above this value (up to +Vin) shuts the regulator off. If the voltage applied to this pin is lower than 1.3V or if this pin is left open, the regulator will be in the "on" condition.
-	6, 7, 8	N.C.	No Connect.

\* Exposed Pad of SOP8-PP package should be externally connected to GND.

## Typical Application (Fixed Output Voltage Versions)

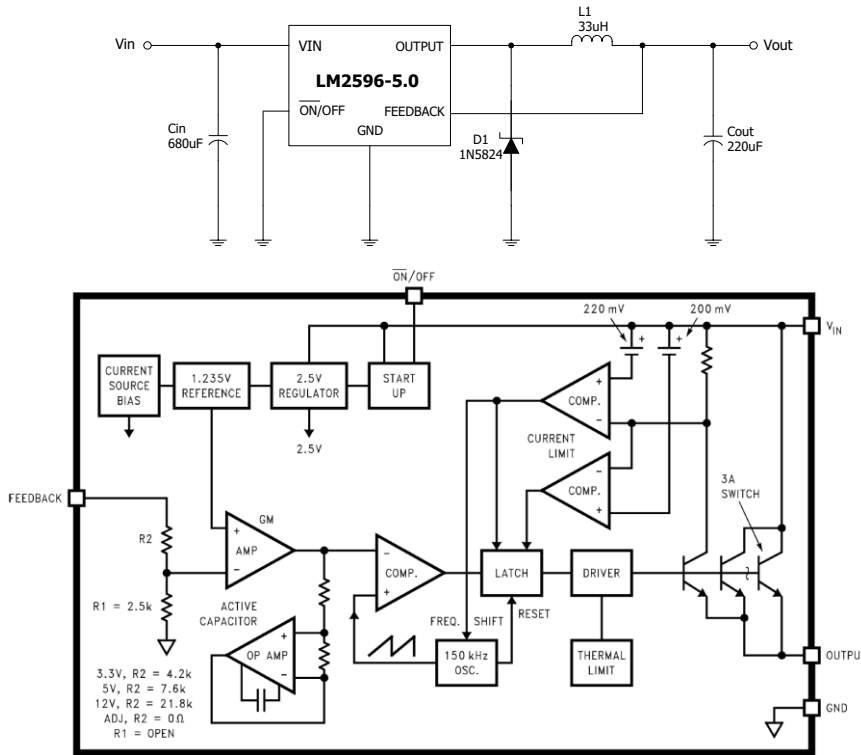

## Absolute Maximum Ratings

Rating	Symbol	Value	UNIT
Maximum Supply Voltage	V <sub>in</sub>	45	V
On/Off Pin Input Voltage	-	-0.3V ≤ V ≤ +V <sub>in</sub>	V
Output Voltage to Ground (Steady-State)	-	-1.0	V
Power Dissipation			
SOP8-PP-8Lead	P <sub>D</sub>	Internally Limited	W
Thermal Resistance, Junction to Ambient	θ <sub>JA</sub>	Contact us	°C/W
Thermal Resistance, Junction to Case	θ <sub>JC</sub>	Contact us	°C/W
TO-220-5Lead	P <sub>D</sub>	Internally Limited	W
Thermal Resistance, Junction to Ambient	θ <sub>JA</sub>	65	°C/W
Thermal Resistance, Junction to Case	θ <sub>JC</sub>	5	°C/W
TO-263-5Lead	P <sub>D</sub>	Internally Limited	W
Thermal Resistance, Junction to Ambient	θ <sub>JA</sub>	70	°C/W
Thermal Resistance, Junction to Case	θ <sub>JC</sub>	5	°C/W
Storage Temperature Range	T <sub>STG</sub>	-60 to +150	°C
Minimum ESD Rating (Human Body Model)	-	2	kV
Lead Temperature (Soldering, 10seconds)	-	260	°C
Maximum Junction Temperature	T <sub>J</sub>	150	°C

**OPERATING RATINGS** (Operating Ratings indicate conditions for which the device is intended to be functional, but do not guarantee specific performance limits. For guaranteed specifications, see the Electrical Characteristics.)

Rating	Symbol	Value.	Unit
Operating Junction Temperature Range	T <sub>J</sub>	-40 to +125	°C
Supply Voltage	V <sub>in</sub>	40	V

#### ELECTRICAL CHARACTERISTICS / SYSTEM PARAMETERS ([Note 1] Test Circuit Figure 2)

(Unless otherwise specified, V<sub>in</sub> = 12V for the 3.3V, 5.0V, and Adjustable version, V<sub>in</sub> = 25V for the 12V version. I<sub>LOAD</sub> = 500 mA. For typical values T<sub>J</sub> = 25°C, for min/max values T<sub>J</sub> is the operating junction temperature range that applies [Note 2], unless otherwise noted.)

Characteristics	Symbol	Min	TYP	Max	Unit
<b>LM2596-3.3V ([Note 1] Test Circuit Figure 2)</b>					
Output Voltage (V <sub>in</sub> =12V, I <sub>LOAD</sub> =0.5A, T <sub>J</sub> =25°C)	V <sub>out</sub>	3.234	3.3	3.366	V
Output Voltage (6.0V≤V <sub>in</sub> ≤40V, 0.5A≤I <sub>LOAD</sub> ≤3.0A)	V <sub>out</sub>				V
T <sub>J</sub> =25°C		3.168	3.3	3.432	
T <sub>J</sub> =-40°C ~ +125°C		3.135	-	3.465	
Efficiency (V <sub>in</sub> =12V, I <sub>LOAD</sub> =3.0A)	η	-	73	-	%

<b>LM2596-5.0V ([Note 1] Test Circuit Figure 2)</b>					
Output Voltage (V <sub>in</sub> =12V, I <sub>LOAD</sub> =0.5A, T <sub>J</sub> =25°C)	V <sub>out</sub>	4.9	5.0	5.1	V
Output Voltage (8.0V≤V <sub>in</sub> ≤40V, 0.5A≤I <sub>LOAD</sub> ≤3.0A)	V <sub>out</sub>				V
T <sub>J</sub> =25°C		4.8	5.0	5.2	
T <sub>J</sub> =-40°C ~ +125°C		4.75	-	5.25	
Efficiency (V <sub>in</sub> =12V, I <sub>LOAD</sub> =3.0A)	η	-	80	-	%

<b>LM2596-12V ([Note 1] Test Circuit Figure 2)</b>					
Output Voltage (V <sub>in</sub> =25V, I <sub>LOAD</sub> =0.5A, T <sub>J</sub> =25°C)	V <sub>out</sub>	11.76	12	12.24	V
Output Voltage (15V≤V <sub>in</sub> ≤40V, 0.5A≤I <sub>LOAD</sub> ≤3.0A)	V <sub>out</sub>				V
T <sub>J</sub> =25°C		11.52	12	12.48	
T <sub>J</sub> =-40°C ~ +125°C		11.4	-	12.6	
Efficiency (V <sub>in</sub> =12V, I <sub>LOAD</sub> =3.0A)	η	-	90	-	%

<b>LM2596-ADJ ([Note 1] Test Circuit Figure 2)</b>					
Feedback Voltage (V <sub>in</sub> =12V, I <sub>LOAD</sub> =0.5A, T <sub>J</sub> =25°C)	V <sub>out</sub>	1.217	1.23	1.243	V
Feedback Voltage(8.0V≤V <sub>in</sub> ≤40V, 0.5A≤I <sub>LOAD</sub> ≤3.0A, V <sub>out</sub> =5.0V)	V <sub>out</sub>				V
T <sub>J</sub> =25°C		1.193	1.23	1.267	
T <sub>J</sub> =-40°C ~ +125°C		1.18	-	1.28	
Efficiency (V <sub>in</sub> =12V, I <sub>LOAD</sub> =3.0A, V <sub>out</sub> =5.0V)	η	-	73	-	%

### 3.0A, 150kHz, Step-Down Switching Regulator

LM2596

Characteristics	Symbol	Min	TYP	Max	Unit
<b>All Output Voltage Versions</b>					
Feedback Bias Current (Vout=5.0V [Adjustable Version Only]) T <sub>J</sub> =25°C T <sub>J</sub> = 0 ~ +125°C	I <sub>b</sub>	11.52 11.4	12 -	12.48 12.6	nA
Oscillator Frequency T <sub>J</sub> =25°C T <sub>J</sub> = 0 ~ +125°C	F <sub>osc</sub>	127 110	150 -	173 173	kHz
Saturation Voltage (I <sub>out</sub> =3.0A [note 3]) T <sub>J</sub> =25°C T <sub>J</sub> = 0 ~ +125°C	V <sub>sat</sub>	- -	1.16 -	1.4 1.5	V
Max Duty Cycle ("0") [Note 4]	DC	-	100	-	%
Current Limit (Peak Current [Note 3]) T <sub>J</sub> =25°C T <sub>J</sub> = 0 ~ +125°C	ICL	3.6 3.4	4.5 -	6.9 7.5	A
Output Leakage Current [Note 5 and 6], T <sub>J</sub> =25°C Output = 0V Output = -1.0V	I <sub>L</sub>	- -	- 2	25 10	μA mA
Quiescent Current [Note 5] T <sub>J</sub> =25°C T <sub>J</sub> = 0 ~ +125°C	I <sub>Q</sub>	- -	5 -	- 10	mA
Standby Quiescent Current (ON/OFF Pin = 5.0V ("off")) T <sub>J</sub> =25°C T <sub>J</sub> = 0 ~ +125°C	I <sub>STBY</sub>	- -	80 -	200 250	μA
ON/OFF Pin Logic Input Level (Test circuit Figure 2) V <sub>out</sub> =0V T <sub>J</sub> =25°C T <sub>J</sub> = 0 ~ +125°C V <sub>out</sub> =Nominal Output Voltage T <sub>J</sub> =25°C T <sub>J</sub> = 0 ~ +125°C	V <sub>IH</sub>  V <sub>IL</sub>	2.0 2.0 - -	1.3 - 1.3 -	- - 0.6 0.6	V
ON/OFF Pin Input Current (Test Circuit Figure 2) V <sub>LOGIC</sub> = 2.5V (Regulator OFF) V <sub>LOGIC</sub> = 0.5V (Regulator ON)	I <sub>IH</sub> I <sub>IL</sub>	- -	5 0.02	15 5.0	μA

- External components such as the catch diode, inductor, input and output capacitors can affect switching regulator system performance. When the LM2596 is used as shown in the Figure 1 test circuit, system performance will be as shown in system parameters section .
- Tested junction temperature range for the LM2596 : T<sub>LOW</sub> = -40°C THIGH = +125°C
- Output (Pin 2) sourcing current. No diode, inductor or capacitor connected to output pin.
- Feedback (Pin 4) removed from output and connected to 0 V.
- Feedback (Pin 4) removed from output and connected to +12V for the Adjustable, 3.3V, and 5.0V versions, and '+25 V for the 12V versions, to force the output transistor "off".C195
- V<sub>in</sub> = 40 V.

## TYPICAL PERFORMANCE CHARACTERISTICS (Circuit of Figure 2)

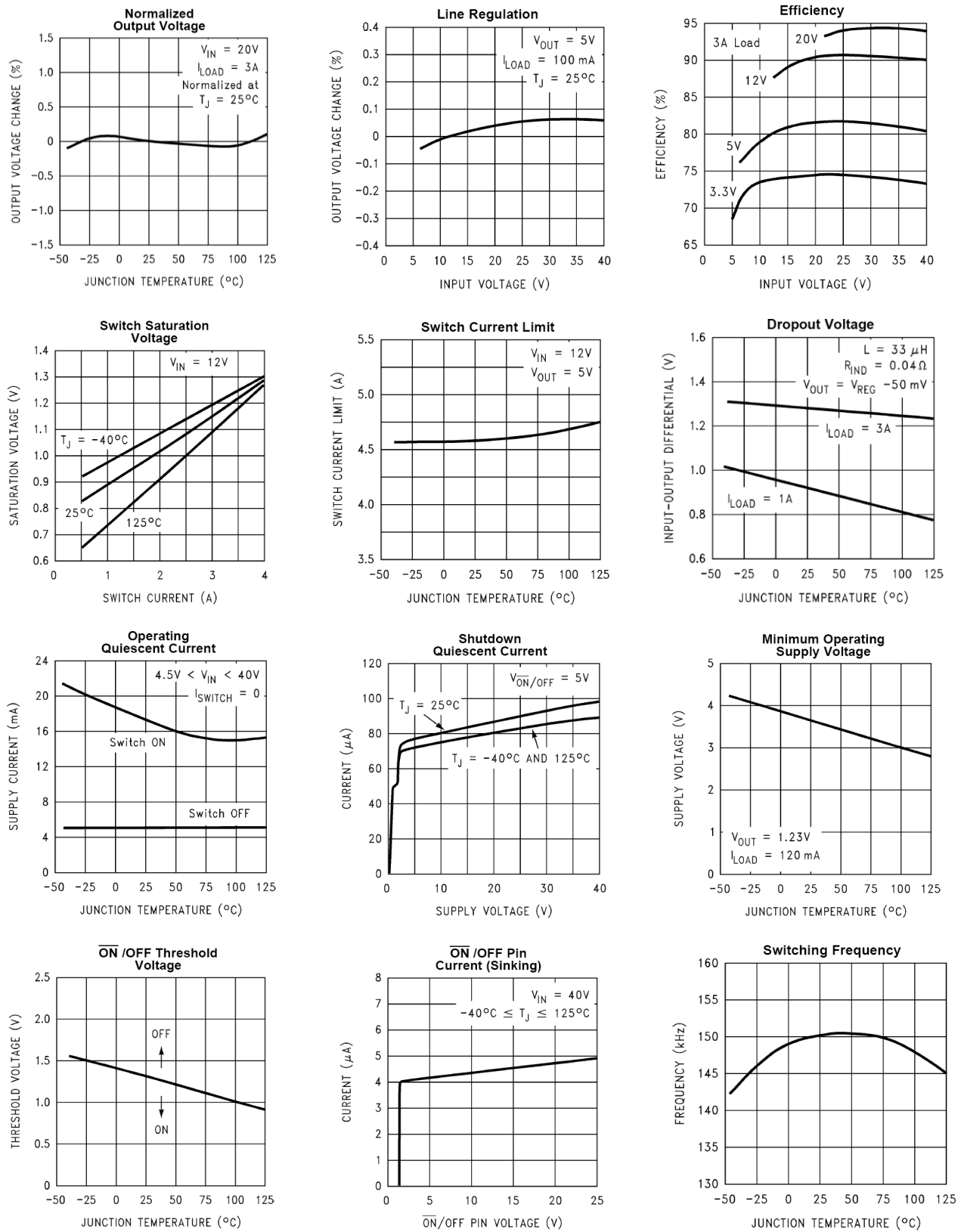

## TYPICAL PERFORMANCE CHARACTERISTICS (Circuit of Figure 2)

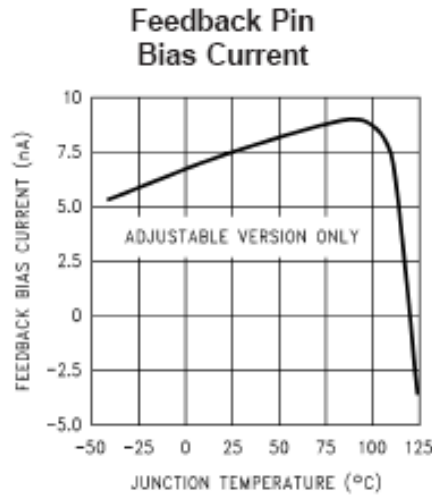

### Continuous Mode Switching Waveforms

$V_{IN} = 20V, V_{OUT} = 5V, I_{LOAD} = 2A$   
 $L = 32 \mu H, C_{OUT} = 220 \mu F, C_{OUT} ESR = 50 m\Omega$

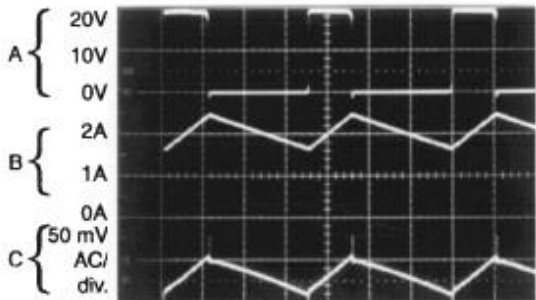

Horizontal Time Base: 2  $\mu s/div.$

- A: Output Pin Voltage, 10V/div.
- B: Inductor Current 1A/div.
- C: Output Ripple Voltage, 50 mV/div.

### Discontinuous Mode Switching Waveforms

$V_{IN} = 20V, V_{OUT} = 5V, I_{LOAD} = 500 mA$   
 $L = 10 \mu H, C_{OUT} = 330 \mu F, C_{OUT} ESR = 45 m\Omega$

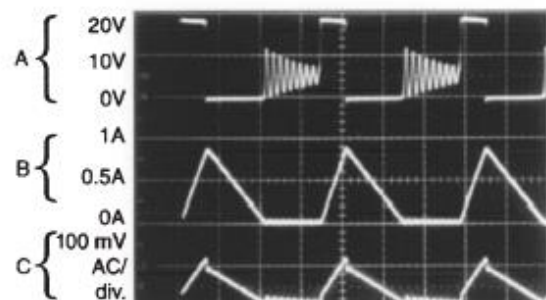

Horizontal Time Base: 2  $\mu s/div.$

- A: Output Pin Voltage, 10V/div.
- B: Inductor Current 0.5A/div.
- C: Output Ripple Voltage, 100 mV/div.

### Load Transient Response for Continuous Mode

$V_{IN} = 20V, V_{OUT} = 5V, I_{LOAD} = 500 mA \text{ to } 2A$   
 $L = 32 \mu H, C_{OUT} = 220 \mu F, C_{OUT} ESR = 50 m\Omega$

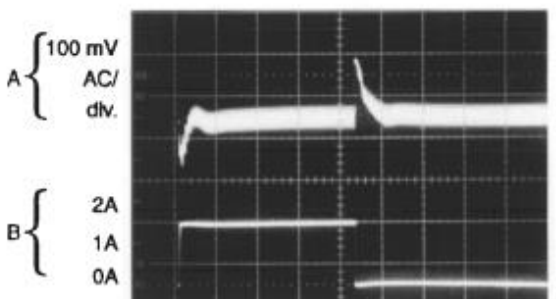

Horizontal Time Base: 100  $\mu s/div.$

- A: Output Voltage, 100 mV/div. (AC)
- B: 500 mA to 2A Load Pulse

### Load Transient Response for Discontinuous Mode

$V_{IN} = 20V, V_{OUT} = 5V, I_{LOAD} = 500 mA \text{ to } 2A$   
 $L = 10 \mu H, C_{OUT} = 330 \mu F, C_{OUT} ESR = 45 m\Omega$

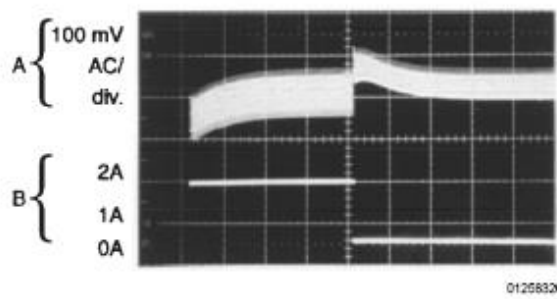

Horizontal Time Base: 200  $\mu s/div.$

- A: Output Voltage, 100 mV/div. (AC)
- B: 500 mA to 2A Load Pulse

## Test Circuit and Layout Guidelines

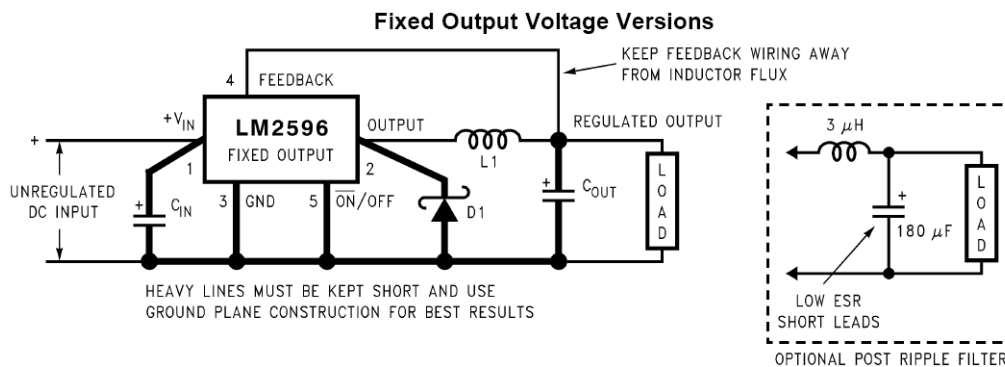

$C_{IN} = 470\mu F, 50V, C_{OUT} = 220\mu F, 25V$  (Aluminum Electrolytic Nichicon "PL Series")

$D1 = 5A, 40V$  Schottky Rectifier, IN5825

$L1 = 68\mu H, L38$

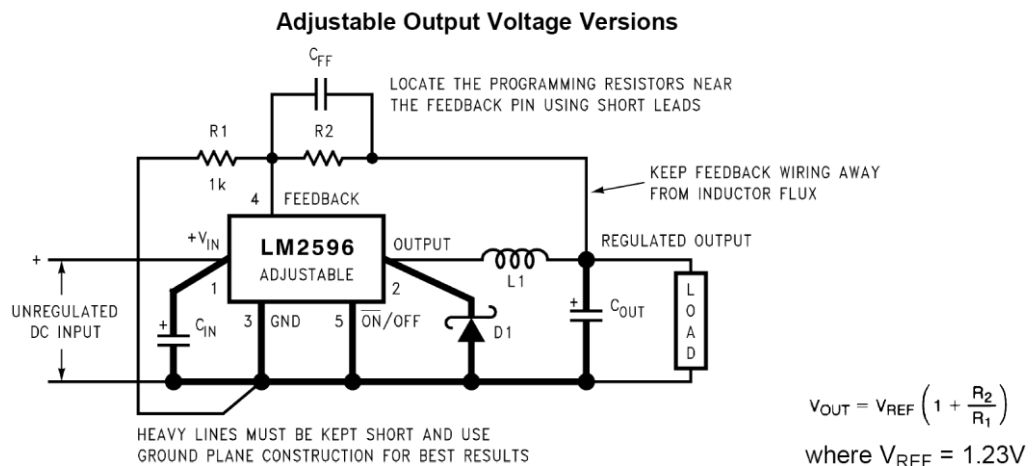

$C_{in} = 470\mu F, 50V, C_{out} = 220\mu F, 35V$  (Aluminum Electrolytic Nichicon "PL Series")

$D1 = 5A, 40V$  Schottky Rectifier, IN5825

$L1 = 68\mu H, R1 = 1\text{ k}\Omega, 1\%, R2 = R1 \times (V_{out} / V_{ref} - 1)$

$$V_{OUT} = V_{REF} \left( 1 + \frac{R_2}{R_1} \right)$$

where  $V_{REF} = 1.23V$

As in any switching regulator, layout is very important. Rapidly switching currents associated with wiring inductance can generate voltage transients which can cause problems. For minimal inductance and ground loops, the wires indicated by heavy lines should be wide printed circuit traces and should be kept as short as possible. For best results, external components should be located as close to the switching IC as possible using ground plane construction or single point grounding. If open core inductors are used, special care must be taken as to the location and positioning of this type of inductor. Allowing the inductor flux to intersect sensitive feedback, IC ground path and COUT wiring can cause problems. When using the adjustable version, special care must be taken as to the location of the feedback resistors and the associated wiring. Physically locate both resistors near the IC, and route the wiring away from the inductor, especially an open core type of inductor.

### REVISION NOTICE

The description in this datasheet is subject to change without any notice to describe its electrical characteristics properly.