

# 承认书

## SPECIFICATION FOR APPROVAL Switching power Supply/开关电源

客户:

**CUSTOMER:** ICB

产品描述:

**DESCRIPTION:** Input:100~240V 0.6A 50/60Hz Output: DC5V4A

机种型号:

**OUR MODEL NO:** BSG25W-0504000

样品编号:

日期:

**SAMPLE NO:** \_\_\_\_\_

**DATE:** 2023/09/12

产品颜色:

**SAMPLE COLOR:**Black



White



APPROVAL SIGNATURE/客户确认		
核准/APPROVED BY	审核/CHECKED BY	检测/TESTED BY

Manufacturer/制造商		
业务/SALES	核准/APPROVED BY	设计/DESIGNED BY

型号/Our model:BSG25W-0504000

客户/Customer: ICB

日期/Date:2023-9-12

样品编号/SAMPLE No:

版本目录/Rev. List

版本/Rev.	日期/Date	描述/ Description	制订/Design

## Table of contents

1、描述/ DESCRIPTION.....	3
2、输入特性/INPUT CHARACTERISTICS .....	3
3、输出特性/OUTPUT CHARACTERISTICS.....	4-5
4、保护功能/PROTECTION FUNCTION.....	5
5、环境要求/ENVIRONMENTAL REQUIREMET.....	5~6
6、安全及 EMI 要求/SAFETY AND EMC REQUIREMENT.....	6
7、结构参数/MECHANICAL REQUIREMENT.....	7
8、线材/CORD .....	8
9、铭牌附图/LABEL.....	9
10、包装说明/PACKING.....	10

型号/Our model:BSG25W-0504000

客户/Customer: ICB

日期/Date:2023-9-12

样品编号/SAMPLE No:

## 1、描述/ DESCRIPTION:

本规格书适应于 BSG25W-0504000 型号的开关电源.

The purpose of the document is to specify the functional requirements of a 18W switching power supply.

## 2、输入特性/INPUT CHARACTERISTICS:100-240V

### 2.1 输入电压/Input Voltage:AC100V-240V

额定电压/Rated Voltage:100~240Vac

调整范围/Variation Range:90-264Vac

### 2.2 输入频率/INPUT FREQUENCY:

额定频率/ Rated Frequency: 50/60Hz.

调整频率/Variation Frequency:47-63Hz

### 2.3 输入电流/INPUT CURRENT:

当输入交流电压为额定值的下限电压负载满载时,最大输入交流电流 0.5A.

0.5Amps max At any input voltage and rated, DC output rated load.

### 2.4 浪涌电流/INRUSH CURRENT:

当输出为额定负载,环境温度为 25°C,输入 240Vac 冷态起机时的最大浪涌电流小于 30A.

30 Amps Max. Cold start at 240Vac input, with rated load and 25°C ambient.

### 2.5 AC 漏电流/AC LEAKAGE CURRENT

当输入电压 240Vac 时,最大漏电流为 0.25mA.

0.25mA Max.At240Vac input.

型号/Our model:BSG25W-0504000

客户/Customer: ICB

日期/Date:2023-9-12

样品编号/SAMPLE No:

### 3、输出特性/OUTPUT CHARACTERISTICS:

#### 3.1 输出功率/Power output

电压 Voltage	最小负载 Min. Load	额定负载 Rated. Load	峰值功率 Peak	输出功率 Output power
5Vdc	0.00A	4A	25.2W	20W

#### 3.2 负载特性,调整率/Combined Load/Line Regulation

电压 Voltage	最小负载 Min. Load	额定负载 Rated. Load	线性调整 Line Regulation	电压范围 Voltage range
5Vdc	0.00A	4A	±5%	5.25V-4.75V

#### 3.3 纹波和噪音 Ripple and Noise:

测试条件:在额定电压及额定负载条件下,使用示波器带宽为 20MHz 连接到充电器的输出端,同时输出端并联一个 47uF 的电解电容和一个 0.1uF 的瓷片电容.

Under nominal voltage and nominal load,the ripple and noise are as follows when measure with Max.Bandwidth of 20MHz and Parallel 47uF/0.1uF,crossed connected at testing point.

电压 Voltage	最大纹波/最大噪音 Ripple and Noise(Max.)
+5Vdc	3000mV p-p

#### 3.4 启动延迟时间/Turn on delay time:

当输入 115Vac 和输出最大负载时,最大启动时间为 3S.

**3Second Max.at 115Vac input and output Max.load.**

#### 3.5 上升时间/Rise time:

当输入 115Vac 和输出最大负载时最大时间为 40 mS.

**40 mS Max.at 115Vac input and output Max load.**

#### 3.6 保持时间/Hold up time:

当输入 115Vac 和输出最大负载时,最小保持时间为 5 mS .

**5 mS Min.at 115Vac input and output Max.Load.**

#### 3.7 效率/Average Effivency

当输入 115/230Vac 时输出 100%Load 75%Load 50%Load 25%Load 负载平均效率最小 88%。适配器满足能效 V6

**Average Effivency 88Min, At 115/230Vac input and output 100%Load 75%Load 50%Load 25%Load Adapter meet effivency Level VI**

型号/Our model:BSG25W-0504000

客户/Customer: ICB

日期/Date:2023-9-12

样品编号/SAMPLE No:

#### 4、保护功能/PROTECTION FUNCTION:

##### 4.1 短路测试/Short circuit test:

该电源供给器在短路解除时能正常工作恢复.

**The power supply will be auto recovered when short circuit faults remove.**

##### 4.2 过流保护/Over current Protection:

过流故障排除后,电源将自动恢复正常工作.

**The power supply will be auto recovered when over current faults remove.**

##### 4.3 过压保护/Over Voltage Protection:

当输出电压超过额定电压的 120%~170%时,电源将保护,故障排除后能恢复正常工作.

**The power supply will auto recovered when faults remove 120%~170%.**

#### 5、环境要求/ENVIRONMENTAL REQUIREMET:

##### 5.1 工作温度/Operating Temperature:

0°C-40°C,满载,正常工作.

**0°C to 40°C,Full load, Normal operation.**

##### 5.2 储藏温度/Storage Temperature:-20°C to 80°C

带外壳/With package

##### 5.3 工作湿度/Relative Humidity:

5%(0°C)~90%(40°C),72 小时,满载,正常工作.

**5%(0°C)~90%(40°C)RH,72Hrs,Full load, Normal operating.**

##### 5.4 振动/Vibration:

###### 1. 测试标准:国际电工电子委员会

**Operating: IEC 721-3-3 3M3**

5~9Hz,A=1.5mm

加速度(9~200Hz,Acceleration 5m/S<sup>2</sup>)

###### 2. 运输/Transportation:

IEC 721-3-2 2M2

5-9Hz,A=3.5mm

9~200Hz,加速度 Acceleration=5m/S<sup>2</sup>

200~500Hz,加速度 Acceleration=15m/S<sup>2</sup>

型号/Our model:BSG25W-0504000

客户/Customer: ICB

日期/Date:2023-9-12

样品编号/SAMPLE No:

### 3. 轴向振动/Axes,10 cycles per axis.

在测试过程中不能出现永久性的损坏.

**No permanent damage may occur during testing.**

在电源开启和关闭后,样机能够恢复到最初条件.

**The SAMPLE has to restore to its original situation after power off/on..**

### 5.5 跌落试验/Dropping Packed:

插墙式跌落高度为 1 米、桌面式跌落高度为 760mm;

**1M for wallmount type and 760mm for desktop type as above described.**

测试台面是厚 13mm 的夹木板, 离地面高 19-20mm

**The horizontal surface consists of hardwood at least 13mm thick, mounted on two layers of plywood**

**each 19mm to 20mm thick,all supported on a concrete or equivalent non-resilient floor.**

### 6、安全要求/SAFETY REQUIREMENT:

6.1 安全:符合标准 UL/CUL-(UL60950-1),TUV/GS-(EN60950-1),CCC-(GB4943) , CE-(J60950-1),

**Safety: accord with UL/CUL-(UL60950-1),TUV/GS-(EN60950-1),CCC-(GB4943) , PSE-(J60950-1),**

6.2 高压/DIELECTRIC STRENGTH Hi-Pot:

初级对次级/Primary to secondary:3750Vac10mA/3S for type test.

6.3 绝缘抗阻/ Insulation resistance:

初级对次级/Primary to secondary:10MΩ min at 500V DC.

6.4 EMI 标准/EMI STANDARD

Meets the Limits of/测试符合

<1>.Fcc part15 class B rules

<2>.EN55022 class B rules

<3>.GB9254-1998,GB17625.1-2003

型号/Our model:BSG25W-0504000

客户/Customer: ICB

日期/Date:2023-9-12

样品编号/SAMPLE No:

## 7、 结构参数/MECHANICAL REQUIREMENT:

### 7.1 外壳/Enclosure:

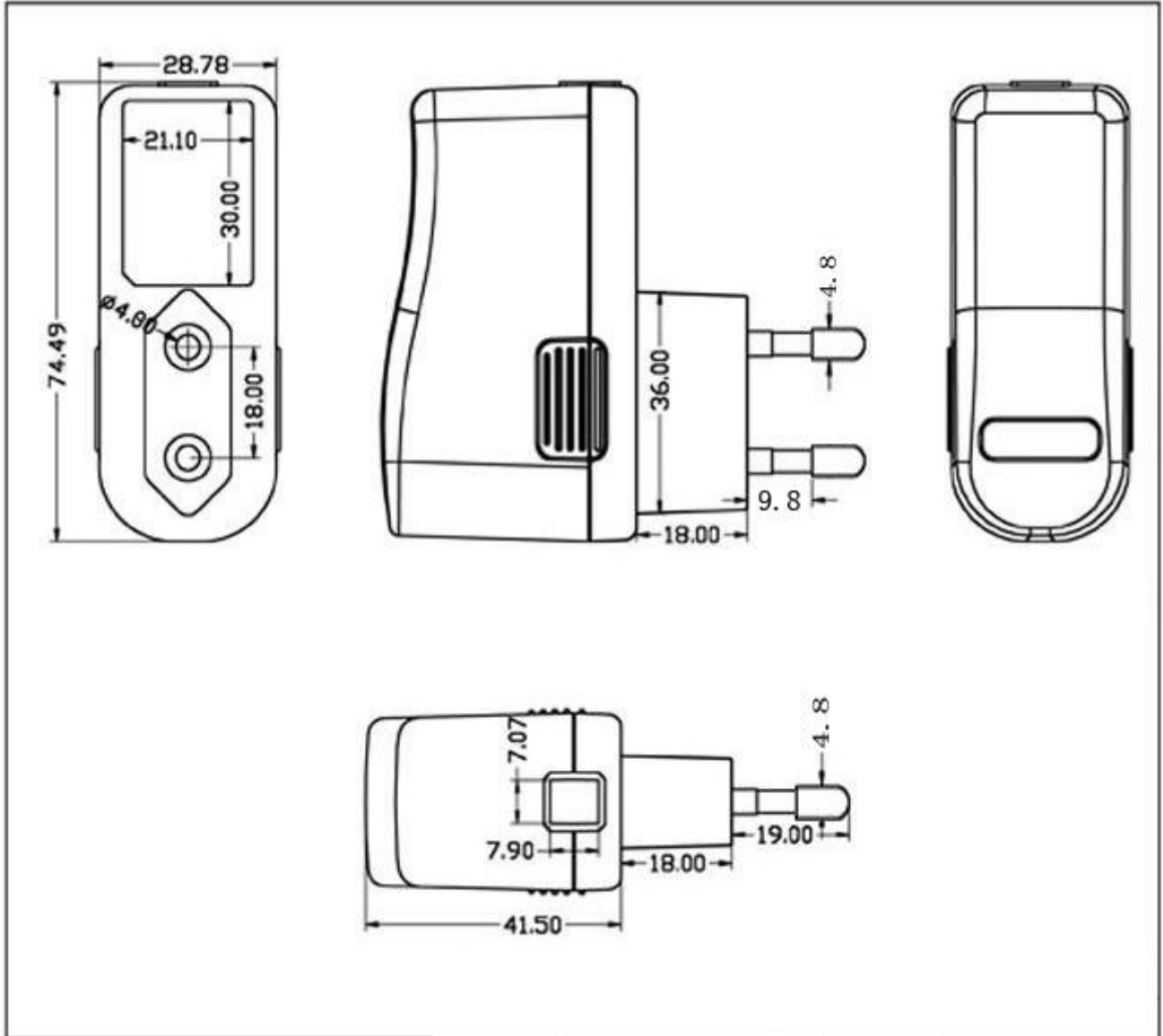

型号/Our model:BSG25W-0504000

客户/Customer: ICB

日期/Date:2023-9-12

样品编号/SAMPLE No:

8、线材/CORD:

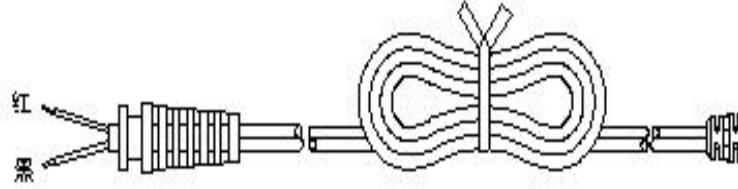

L=1M 2464 20#

DC: 5.5\*2.1

型号/Our model:BSG25W-0504000

客户/Customer: ICB

日期/Date:2023-9-12

样品编号/SAMPLE No:

9、铭牌/LABEL:

待定

型号/Our model:BSG25W-0504000

客户/Customer: ICB

日期/Date:2023-9-12

样品编号/SAMPLE No:

10、包装说明/PACKING:

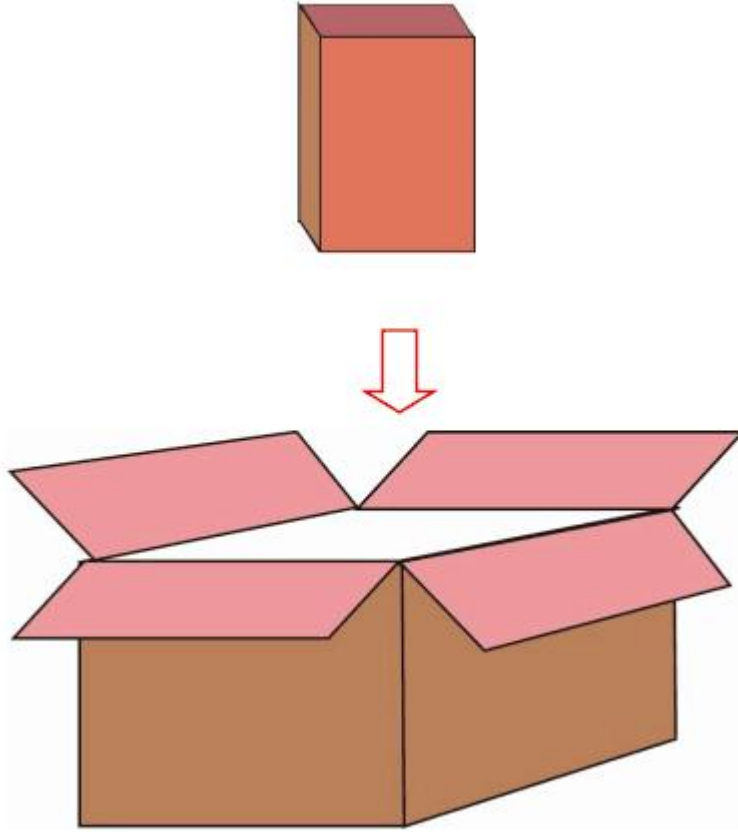

10\*10=100PCS