

Specification Sheet

Model No. : WTY101ND06CW

Description : 10.1 inch 1024 RGB x 600 High Resolution
Transmissive Type Color Active Matrix
TFT LCD Module LVDS Interface.Option
Capacitance Touch Panel.

CONTENTS

1. OVERVIEW	4
2. ABSOLUTE MAXIMUM RATINGS	5
3. ELECTRICAL CHARACTERISTICS	6
3.1 TFT LCD.....	6
3.2 TFT-LCD Current Consumption.....	7
3.3 Power, Signal sequence.....	7
3.4 Backlight.....	8
4. INTERFACE CONNECTION	9
4.1 CN1 (Input Signal).....	9
4.2 CN2 (LED backlight).....	11
5. INPUT SIGNAL(DE ONLY MODE)	12
5.1 Timing Specification.....	12
6. Timing sequence(Timing chart)MECHANICAL DIMENSION	14
6.1	12
6.2 Front Side.....	14
6.3 Rear Side.....	15
7. OPTICAL CHARACTERISTICS	16
8. RELIABILITY TEST	18
8.1. Temperature and humidity.....	18
8.2. Shock and Vibration.....	18
8.3 Electrostatic Discharge.....	18
8.4. Judgment standard.....	18
9. WARRANTY	19

1. OVERVIEW

CLAA101ND06 CW is 10.1" color TFT-LCD (Thin Film Transistor Liquid Crystal Display) module composed of LCD panel, driver ICs, control circuit and LED backlight. By applying 1024x600 images are displayed on the 10.1" diagonal screen. Display 16.2M colors by R.G.B signal input.

General specification are summarized in the following table:

ITEM	SPECIFICATION			
Display Area (mm)	222.72(W) x 125.28(H)			
Number of Pixels	1024(H) x 3 (RGB) x 600(V)			
Pixel Pitch (mm)	0.2175(W) x 0.2088(H)			
Color Pixel Arrangement	RGB vertical stripe			
Display Mode	Normally white			
Number of Colors	16.2M			
Brightness (cd/m ²)	380 (Typ)			
Response Time (ms)	25 (Typ.)			
Optimum Viewing Direction	6 O'clock(Max contrast ratio, Gray level inversion)			
Contrast Ratio	600:1 (typ)			
Viewing Angle (CR ≥ 10)	140degree (Horizontal.)			
	120degree (Vertical)			
Power Consumption (W)	3.16 (Typ)			
Interface connection	LVDS			
Module Size (mm)		Min.	Typ.	Max.
	Horizontal(H)	234.7	235	235.3
	Vertical(V)	142.7	143	143.3
	Depth(D)	4.2	4.5	4.8
Module Weight (g)	285 (Typ)			
Backlight Unit	LED			
Surface Treatment	Anti-Glare			

2. ABSOLUTE MAXIMUM RATINGS

The following are maximum values which, if exceeded, may cause faulty operation or damage to the unit.

Item	Symbol	Min.	Max.	Unit	Note
Digital Supply Voltage	DVDD DVDD_LVDS	-0.3	3.96	V	
Analog Supply Voltage	AVDD	-0.5	14.85	V	
Gate On Voltage	VGH	-0.3	40	V	
Gate Off Voltage	VGL	-20	0.3	V	
Gate On-Gate Off Voltage	VGH-VGL	12	40	V	
Signal Input Voltage	NIND0 ~ NIND3 PIND0 ~ PIND3 NINC,PINC	-0.5	5	V	
Forward Current (per LED)	I _f	-	30	mA	
Reverse Voltage (per LED)	V _R	-	5	V	
Pulse forward current (per LED)	I _{fp}	-	100	mA	Note 1,2
Operating temperature	T _{opa}	-20	70	°C	Note 3
Storage temperature	T _{stg}	-30	80	°C	Note 3

Note 1: I_{fp} Conditions : Pulse Width ≤10msec ; Duty ≤1/10

Note 2: perating must under the condition as below drawing.

(Ambient Temperature /Allowable Forward Current) Each LED .

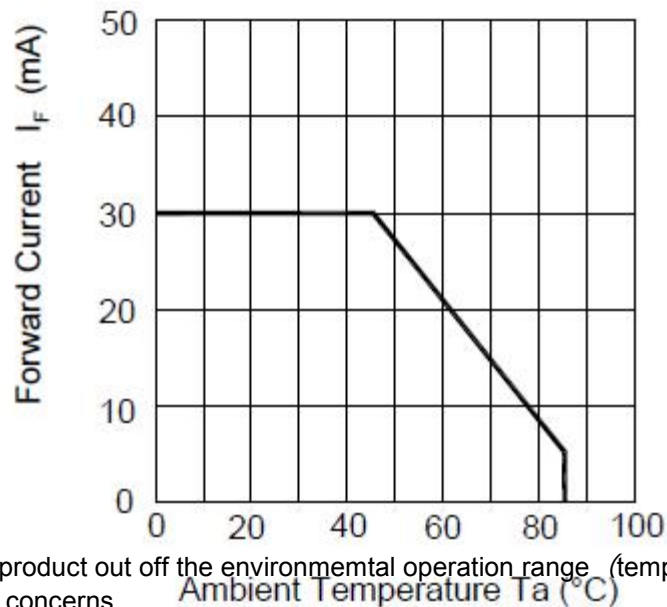

Note 3: If users use the product out off the environmental operation range (temperature and humidity) , it will have visual quality concerns.

3. ELECTRICAL CHARACTERISTICS

3.1 TFT LCD

ITEM	SYMBOL	MIN	TY P	MAX	UNIT	NOTE
Digital Power Supply Voltage For LCD	DVDD VDD_LVDS	3	3.3	3.6	V	
Logic Input Voltage (LVDS:IN+,IN-)	VCM	VID 2	-	2.4 – 2	V	Note 1
	VID	200	-	600	mV	Note 1
	VTH	-	-	100	mV	VCM=1.2 V Note 1
	VTL	-100	-	-	mV	
Analog Power Supply Voltage	AVDD	9.4	9.6	9.8	V	
Gate On Power Supply Voltage	VGH	17	18	19	V	
Gate Off Power Supply Voltage	VGL	-6.6	-6	-5.4	V	
Common Power Supply Voltage	VCOM	3.8	4.0	4.2	V	Note 2
Gamma Voltage	V1	-	9.4 50	-	V	
	V2	-	8.7 69	-	V	
	V3	-	7.5 7	-	V	
	V4	-	-	-	V	
	V5	-	7.1 58	-	V	
	V6	-	6.3 48	-	V	
	V7	-	5.5 42	-	V	
	V8	-	4.9 66	-	V	
	V9	-	4.0 58	-	V	
	V10	-	3.3 08	-	V	
	V11	-	2.8 96	-	V	
	V12	-	2.4 21	-	V	
	V13	-	0.9 92	-	V	
	V14	-	0.2 05	-	V	

Ta=25°C

Note 1: LVDS

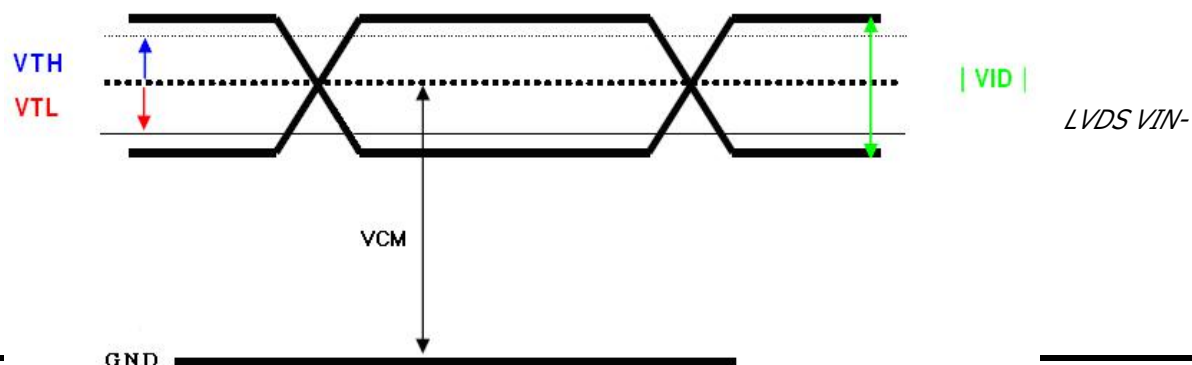

Note 2: Please adjust VCOM to make the flicker level be minimum.

Note 3: The voltage of these pins must be:

$AGND+0.1 < V14 < V13 < V12 < V11 < V10 < V9 < V8;$
 $V7 < V6 < V5 < V4 < V3 < V2 < V1 < AVDD-0.1$



3.2 TFT-LCD Current Consumption

Item	Symbol	Condition	Min.	Typ.	Max.	Unit.	Note.
Gate on Current	IVGH	VGH = 18V	-	0.5	1	mA	Note 1
Gate off Current	IVGL	VGL = -6V	-	0.5	1	mA	Note 1
Digital Current	IDVDD	DVDD = 3.3V	-	40	50	mA	Note 1
Analog Current	IAVDD	AVDD = 9.6V	-	35	45	mA	Note 1
Total Power Consumption	PC		-	480	621	mW	Note 1

Note 1: Typical: Under 256 gray pattern
 Maximum: Under black pattern



256 gray pattern



Black Pattern

3.3 Power, Signal sequence

Power On : DVDD → AVDD/VGL → VGH → Video & Logic Signal → Backlight
 Power Off : Backlight → Video & Logic Signal → VGH → AVDD/VGL → DVDD

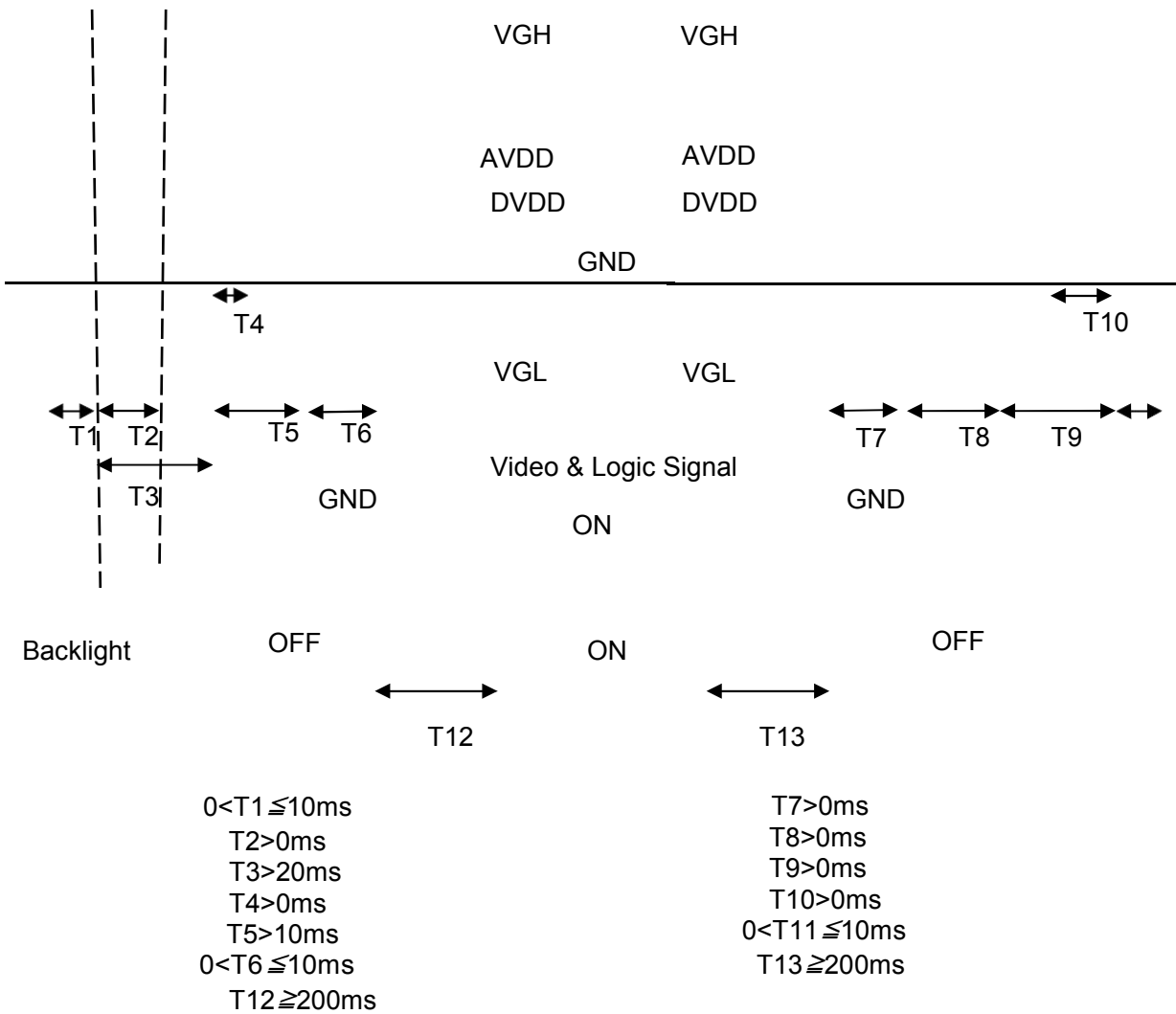

3.4 Backlight

Ta=25°C

ITEM	SYMBOL	CONDITIONS	MIN	TYP	MAX	UNIT	NOTE
LED current	IL	Ta=25°C (20mA/serise)	--	140	--	mA	
LED voltage	VL	Ta=25°C (20mA/serise)	17.4	19.2	21.6	V	
Power consumption	WL	Ta=25°C (20mA/serise)	--	2.680	--	W	
LED Lifetime	-	Ta=25°C IF=20mA	20000	--	--	Hr	

Remarks :

*1)LED Circuit Diagram

*2) A : Anode(+), K : Cathode(-)

*3) Suggestion: Using the constant current control to avoid the leakage light and brightness quality issue.

*4) Definition of Led lifetime : Luminance < Initial luminance 50%.

4. INTERFACE CONNECTION

4.1 CN1 (Input Signal)

Pin NO.	Symbol	Description	Note
1	AGND	Analog ground	
2	AVDD	Analog power	
3	DVDD	Digital power	
4	GND	Digital ground	
5	VCOM	Common voltage	
6	DVDD	Digital power	
7	GND	Digital ground	
8	V14	Gamma correction voltage reference	
9	V13	Gamma correction voltage reference	
10	V12	Gamma correction voltage reference	
11	V11	Gamma correction voltage reference	
12	V10	Gamma correction voltage reference	
13	V9	Gamma correction voltage reference	
14	V8	Gamma correction voltage reference	
15	GND	Digital ground	
16	DVDD_LVDS	LVDS power	
17	GND	Digital ground	
18	PIND3	Positive LVDS differential data input	
19	NIND3	Negative LVDS differential data input	
20	GND	Digital ground	
21	PINC	Positive LVDS differential clock input	
22	NINC	Negative LVDS differential clock input	
23	GND	Digital ground	
24	PIND2	Positive LVDS differential data input	
25	NIND2	Negative LVDS differential data input	
26	GND	Digital ground	
27	PIND1	Positive LVDS differential data input	
28	NIND1	Negative LVDS differential data input	
29	GND	Digital ground	
30	PIND0	Positive LVDS differential data input	
31	NIND0	Negative LVDS differential data input	
32	GND	Digital ground	
33	GND_LVDS	LVDS ground	
34	GRB	Global reset pin. Active low to enter reset state. Suggest to connecting with an RC reset circuit for stability. Normally pull high. (R=10K Ω , C=0.1 μ F)	
35	STBYB	Standby mode, normally pull high STBYB= \uparrow , normal operation STBYB= \downarrow , timing control, source driver will turn off, all output are high-Z	
36	SHLR	Left or right display control	Note 1
37	DVDD	Digital power	
38	UPDN	Up / down display control	Note 1
39	AGND	Analog ground	
40	AVDD	Analog power	
41	VCOM	Common voltage	

42	DITH	Dithering function enable control. Normally pull low DITHER = 1, Enable internal dithering function DITHER = 0, Disable internal dithering function	
43	GND	Digital ground	
44	DVDD	Digital Power	
45	GND	Digital ground	
46	V7	Gamma correction voltage reference	
47	V6	Gamma correction voltage reference	
48	V5	Gamma correction voltage reference	
49	V4	Gamma correction voltage reference	
50	V3	Gamma correction voltage reference	
51	V2	Gamma correction voltage reference	
52	V1	Gamma correction voltage reference	
53	GND	Digital ground	
54	DVDD	Digital power	
55	SELB	6bit/8bit mode select, SELB = "0", LVDS input data is 8bits SELB = "1", LVDS input data is 6bits	Note 2
56	VGH	Positive power for TFT	
57	DVDD	Digital power for Gate IC	
58	VGL	Negative power for TFT	
59	GND	Digital ground for Gate IC	
60	NC	Not connect	

Remarks : Mating connector : 089K60-000100-G2-R (STARCONN)

Note 1: UPDN and SHLR control function

UPDN	SHLR	FUNCTION
0	1	Normal display
0	0	Inverse Left and Right
1	1	Inverse Up and Down
1	0	Inverse Left and Right Inverse Up and Down

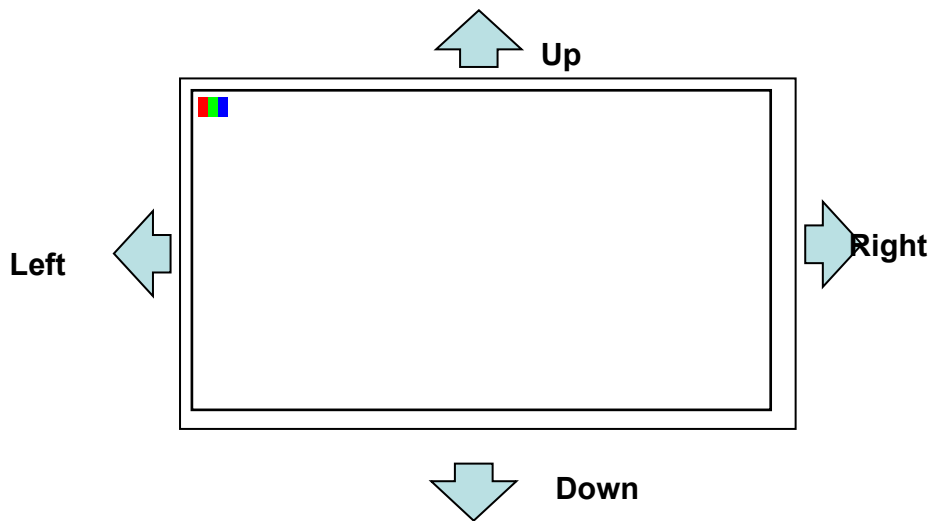

Note 2: if LVDS input data is 6bits, SELB must be set to High
if LVDS input data is 8bits, SELB must be set to Low

DITH and SELB control function

DITH	SELB	FUNCTION
0	1	Colors (262K)
0	0	Colors (262K)
1	1	Colors (262K)
1	0	Colors (16.2M)

4.2 CN2 (LED backlight)

PIN NO	SYMBOL	FUNCTION
1	A	Anode
2	K	Cathode

Note :

Maker:
JST

Input connector : BHSR-02VS-1(JST)

Outlet connector: SM0S2B-BHS-1-
TB(JST)

5. INPUT SIGNAL(DE ONLY MODE)

5.1 Timing Specification

Item		Symbol	Min.	Typ.	Max.	Unit	
LVDS input signal sequence	CLK Frequency	tclk	41.3	51.2	57	MHz	
LCD input signal sequence (Input LVDS Transmitter)	Horizontal	Horizontal total Time	t _H	1324	1344	1364	tCLK
		Horizontal effective Time	t _{HA}	1024			tCLK
		Horizontal Blank Time	t _{HB}	300	320	340	tCLK
	Vertical	Vertical total Time	t _V	625	635	645	t _H
		Vertical effective Time	t _{VA}	600			t _H
		Vertical Blank Time	t _{VB}	25	35	45	t _H

5.2 Timing sequence(Timing chart)

5.2.1 Horizontal Timing Sequence

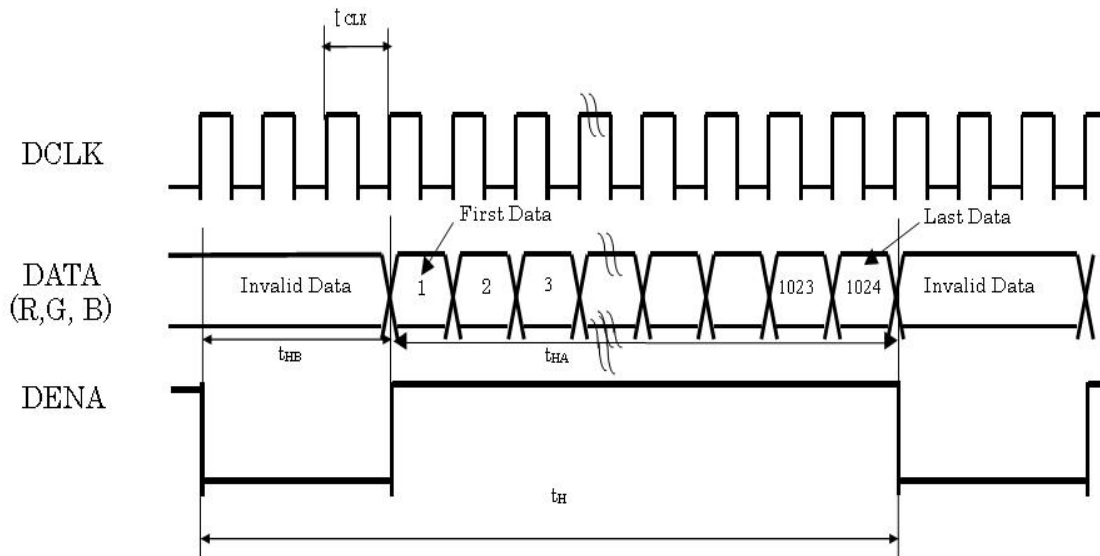

5.2.2 Vertical Timing Sequence

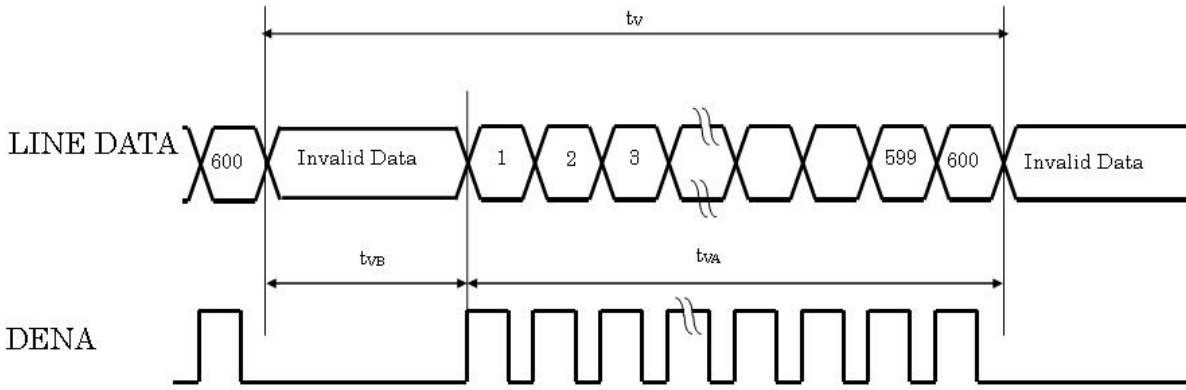

5.2.3 LVDS Input Data mapping

6 Bit LVDS input

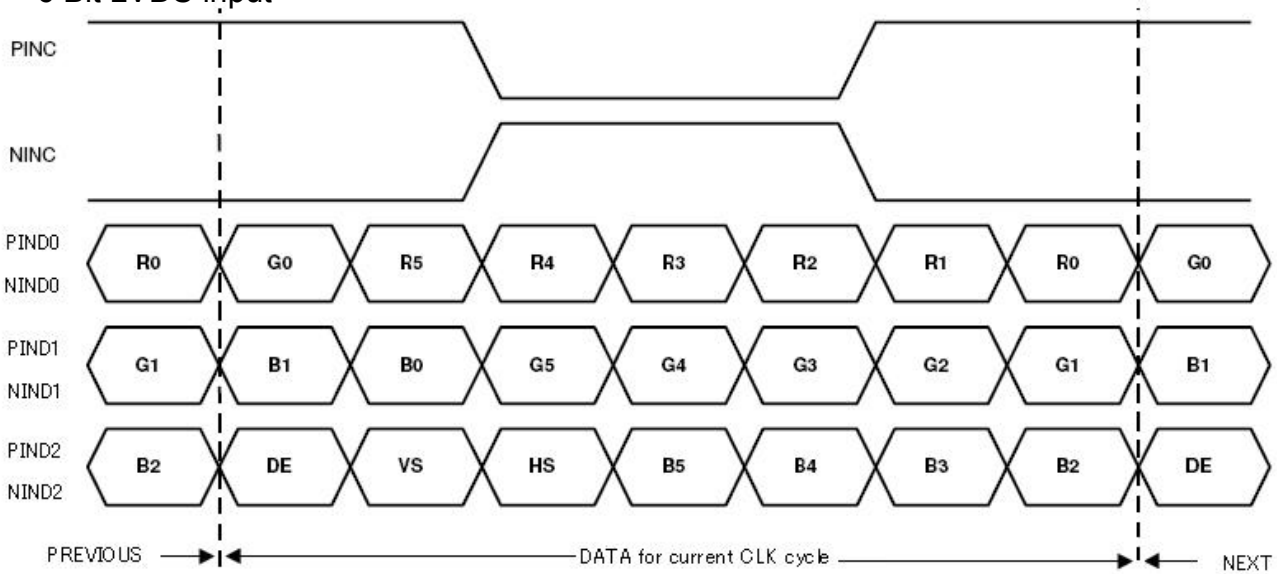

8 Bit LVDS input

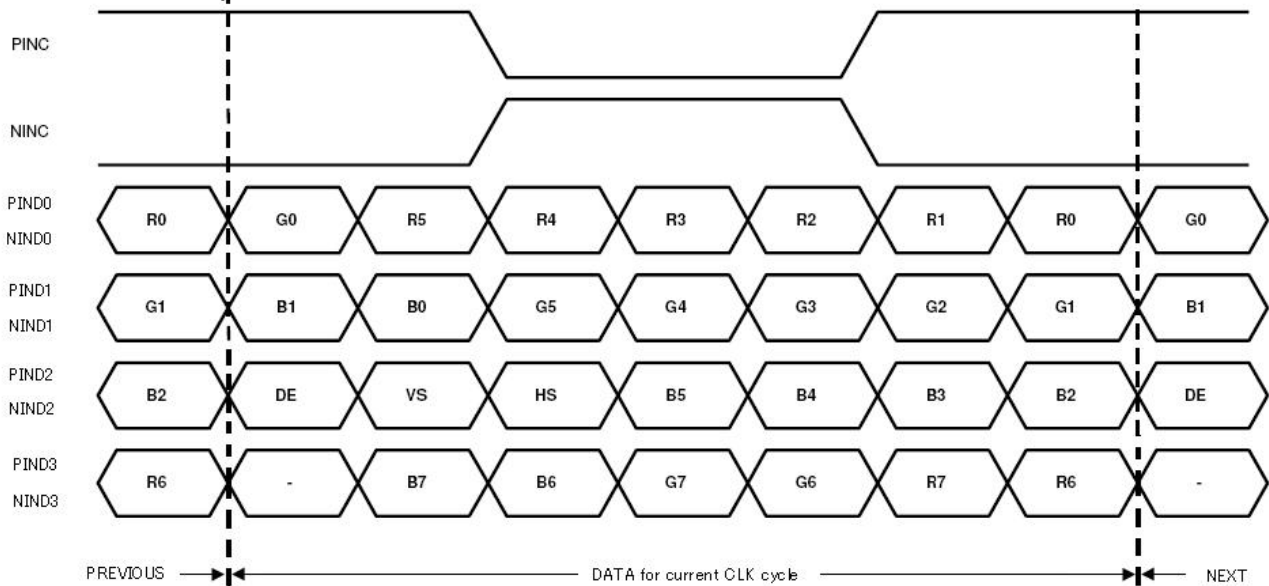

6. MECHANICAL DIMENSION

6.1 Front Side

[Unit : mm]

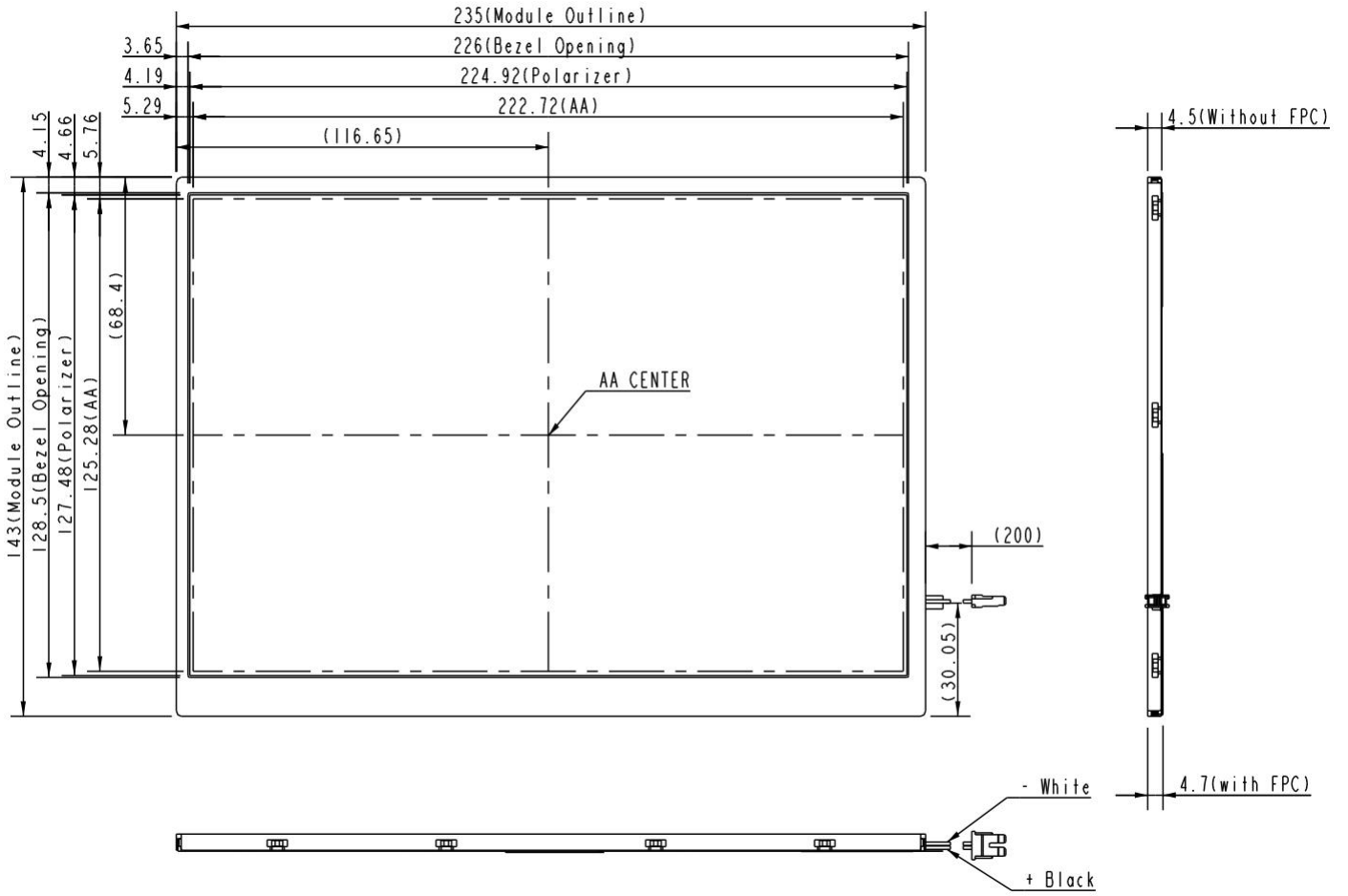

6.2 Rear Side

[Unit : mm]

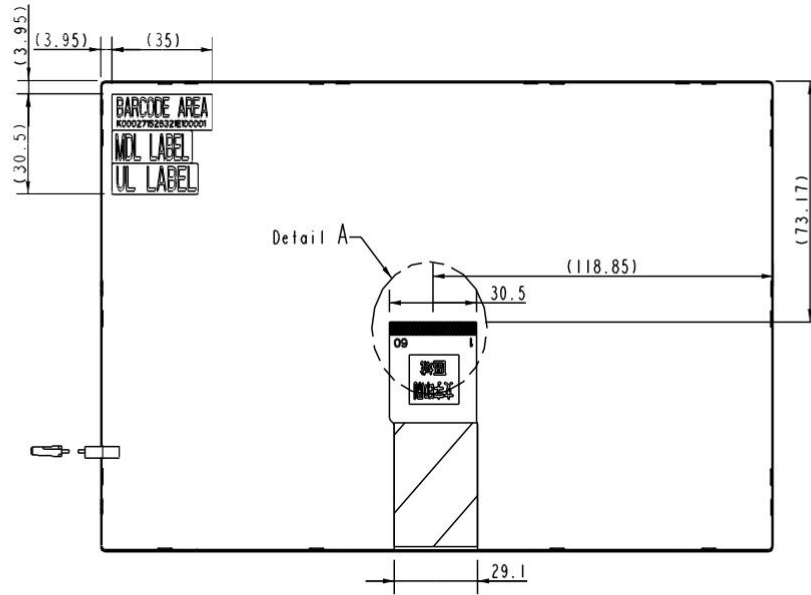

Remark : General tolerance $\pm 0.3\text{mm}$

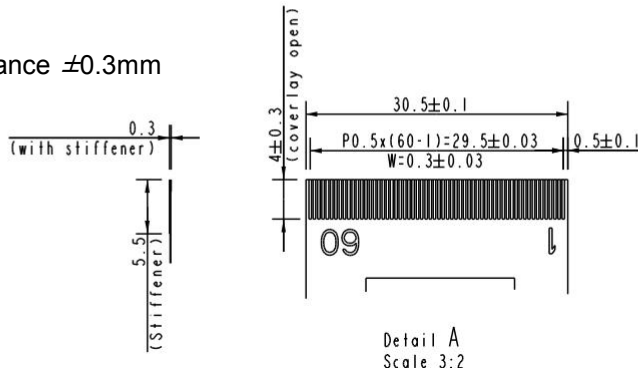

ICbanQ Inc.

Detail A
Scale 3:2

7. OPTICAL CHARACTERISTICS

ITEM	SYMBOL	CONDITI ONS	MIN	TYP	MAX	UNI T	NOTE	
Contrast Ratio	CR	Point-5	500	600	--	- -	1, 2, 3	
Luminance(CEN)	Lw	Point-5				²	1, 3	
Luminance Uniformity	ΔL		70	80	--	%	1, 3	
Response Time (White - Black)	Tr +Tf	Point-5	--	25	40	ms	1, 3, 5	
NTSC	-	Point-5	45	50	--	%	1, 4	
Viewing Angle	Vertical	Upper(θ)	CR \geq 1 0 Point- 5	60	70	--	$^{\circ}$	1, 4
		Down(θ)		40	50	--		1, 4
	Horizontal	Left(ψ)		60	70	--		1, 4
		Right(ψ)		60	70	--	$^{\circ}$	1, 4
Color Coordinate	White	Wx	Point- 5	0.273	0.313	0.353	- -	1, 3
		Wy		0.289	0.329	0.369		
	Red	Rx		0.550	0.590	0.630		
		Ry		0.300	0.340	0.380		
	Green	Gx		0.301	0.341	0.381		
		Gy		0.554	0.594	0.634		
	Blue	Bx		0.117	0.157	0.197		
		By		0.075	0.115	0.155		

Ta = 25°C, VCC=3.3V

Note 1: Measure condition : 25°C \pm 2°C, 60 \pm 10%RH, under10 Lux in the dark room.BM-5A (TOPCON), viewing angle2°, IL=140 mA (Backlightrent) , measurement after lighting on 10 mins.

2°

← L=500mm

Note 2: Definition of contrast ratio : Contrast Ratio (CR)= (White) Luminance of ON \div (Black) Luminance of OFF
CPT Confidential

Note 3: Definition of luminance :

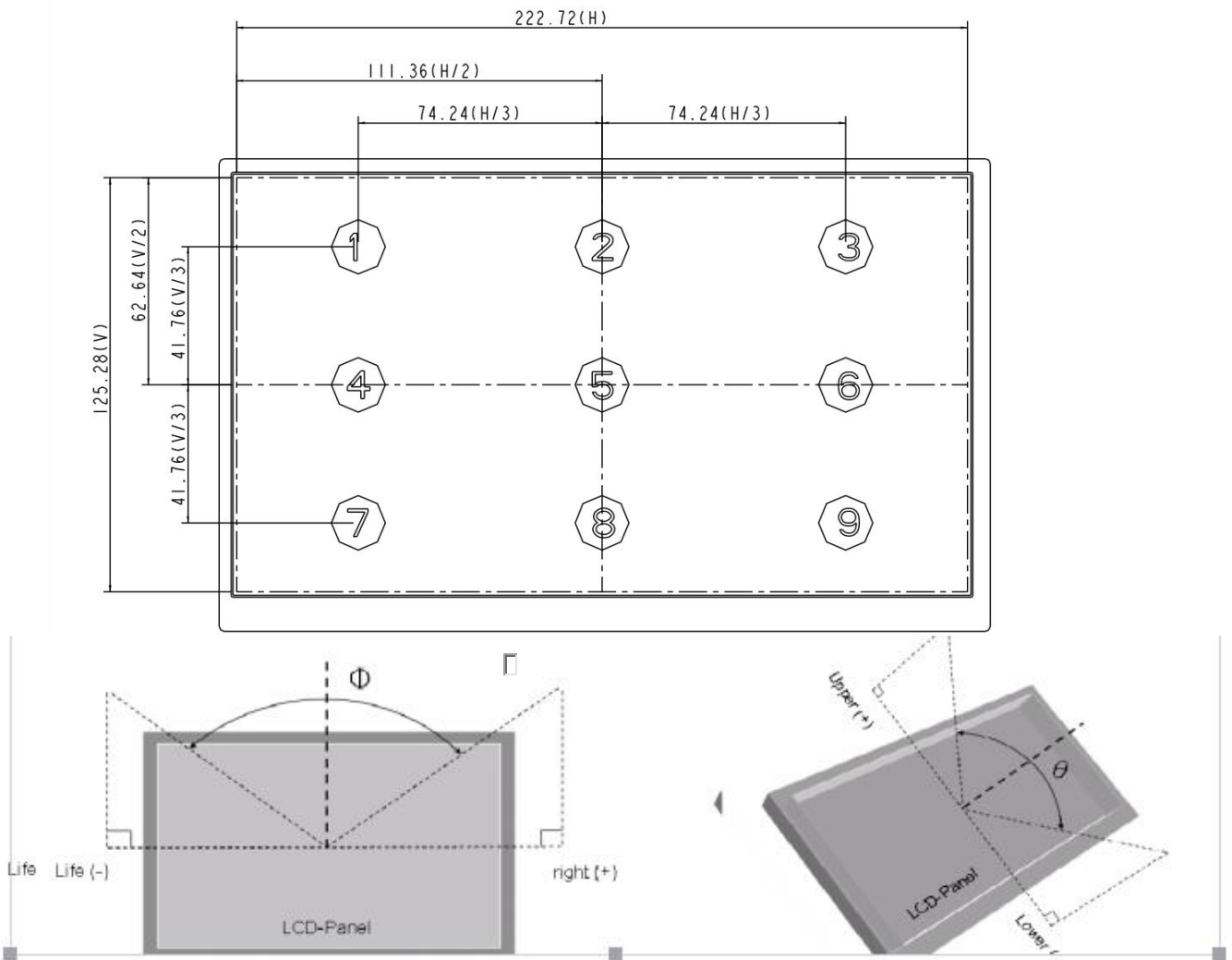

luminance : Measure white luminance on the point 5 as figure.6-1

Definition of Luminance Uniformity: Measure white luminance on the point1~9 as figure.6-1

$$\Delta L = [L(\text{MIN})/L(\text{MAX})] \times 100$$

Measure white luminance on the point 5 as figure.6-1

Definition of Luminance Uniformity: Measure white luminance on the point1~9 as figure.6-1

$$\Delta L = [L(\text{MIN})/L(\text{MAX})] \times 100$$

Fig.asuring point Note 4:

Definition of Viewing Angle(θ, ψ),refeto Fig.7-2 7-1 Meas below :

Fig.7-2 Definition of Viewing Angle Note 5: Definition of Response Time.(White-Black)

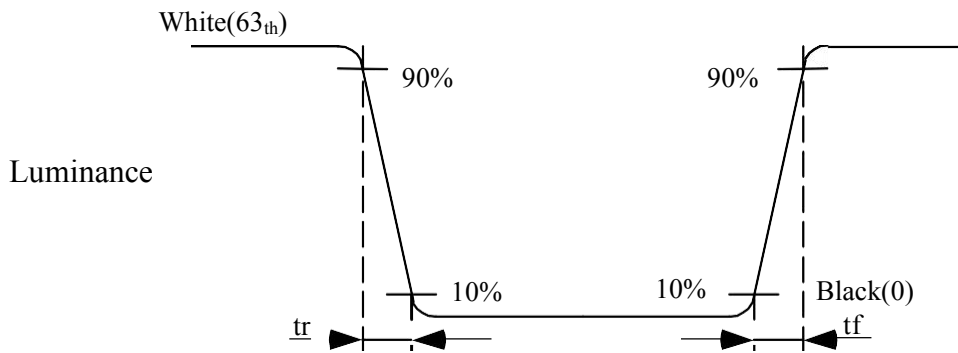

Fig.7-3 Definition of Response Time(White-Black)

8. RELIABILITY TEST

8.1. Temperature and humidity

TEST ITEMS	CONDITIONS	NOTE
High Temperature Operation	70 ℃ ;240hrs	
High Temperature Storage	80 ℃ ; 240hrs	
High Temperature High Humidity Operation	60 ℃ ; 90%RH ;240hrs	No condensation
Low Temperature Operation	-20 ℃ ; 240hrs	Backlight unit always turn on
Low Temperature Storage	-30 ℃ ; 240hrs	
Thermal Shock	-30 ℃(0.5hr) ~ 80 ℃(0.5hr) ; 200 Cycles	
Image Sticking	25 ℃ ± 2 ℃ ; 4hrs	Note 1

Note 1. :

Condition of Image Sticking test : 25 ℃ ± 2 ℃

Operation with test pattern sustained for 4hrs, then change to gray pattern immediately.

After 5 mins, the mura must be disappeared completely .

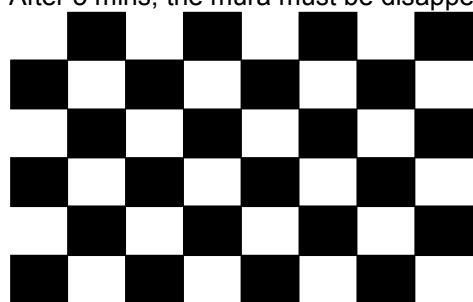
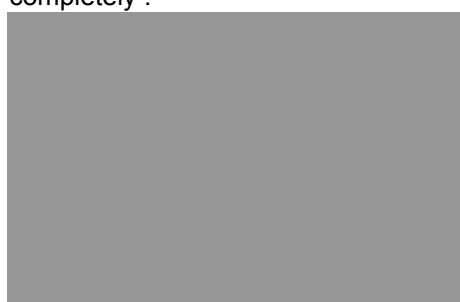

Image Sticking -pattern



Mid-Gray pattern

8.2. Shock and Vibration

TEST ITEMS	CONDITIONS
Shock (Non-operation)	<ul style="list-style-type: none"> Shock level: 980m/s²(equal to 100G). Waveform: half sinusoidal wave,6ms. Number of shocks: ±X,±Y,±Z axes for a total of six shock inputs.
Vibration (Non-operation)	<ul style="list-style-type: none"> Frequency range:8~33.3Hz Stoke : 1.3 mm Vibration: sinusoidal wave, perpendicular axis(both x, z axis: 2hrs ,y axis: 4hrs). Sweep: 2.9G,33.3 Hz -400 Hz Cycle time: 15 min

8.3 Electrostatic Discharge

TEST ITEM	CONDITIONS	Note
ESD	150pF, 330Ω, ±8kV&±15kV air& contact test	1,3
	200pF, 0Ω, ±200V contact test	2,3

Note 1: LCD glass and metal bezel

Note 2: IF connector pins

Note 3: TFT-LCD power off

8.4. Judgment standard

The Judgment of the above test should be made as follow:

Pass:Normal display image with no obvious non-uniformity and no line defect.Partial transformation of the module parts should be ignored.

Fail: No display image, function NG, or line defects.

9. WARRANTY

9.1 The period is within 12 months since the date of shipping out under normal using and storage conditions.

9.2 The warranty will be avoided in case of defect induced by customer