



SPECIFICATION FOR LCM MODULE

MODULE NO.: CBG240064A00-YHY
DOC.REVISION: 01

Customer Approval:

--

	SIGNATURE	DATE
PREPARED BY (RD ENGINEER)		Apr-28-2005
PREPARED BY (QA ENGINEER)		
CHECKED BY		
APPROVED BY		



DOCUMENT REVISION HISTORY

Version	DATE	DESCRIPTION	CHANGED BY
00	Apr-22-2005	First issue	
01	Apr-28-2005	Modify power supply for Back light(4.2V)	



CONTENTS

1. Functions & Features	1
2. Mechanical specifications	1
3. Block diagram	1
4. Dimensional Outline	2
5. Pin description	3
6. Maximum absolute limit	4
7. Electrical characteristics	4
8. The /RES (RESET) Terminal	5
9. Timing Characteristics	6
10. Control and display command	7
11. Recommended Initialization	8
12. Backlight specification	9
13. Electro-Optical characteristics	9
14. Quality Specifications	10~18



1. FUNCTIONS & FEATURES

- 1.1. Format : 240x64 Dots
- 1.2. LCD mode : STN /positive Transflective mode / yellow-green
- 1.3. Viewing direction : 6 o'clock
- 1.4. Driving scheme : 1/64 Duty cycle, 1/9 Bias
- 1.5. Power supply voltage(V_{DD}) : 5.0V
- 1.6. LCD driving voltage : 12V
- 1.7. Operation temp : -20~70°C
- 1.8. Storage temp : -30~80°C
- 1.9. Backlight color : Yellow-Green (side)

2. MECHANICAL SPECIFICATIONS

- 2.1. Module size : 180.0mm(L)*65.0mm(W)* Max14.0(H)mm
- 2.2. Viewing area : 132.0mm(L)*39.0mm(W)
- 2.3. Dot pitch : 0.53mm(L)*0.53mm(W)
- 2.4. Dot size : 0.49mm(L)*0.49mm(W)
- 2.5. Weight : Approx.

3. BLOCK DIAGRAM

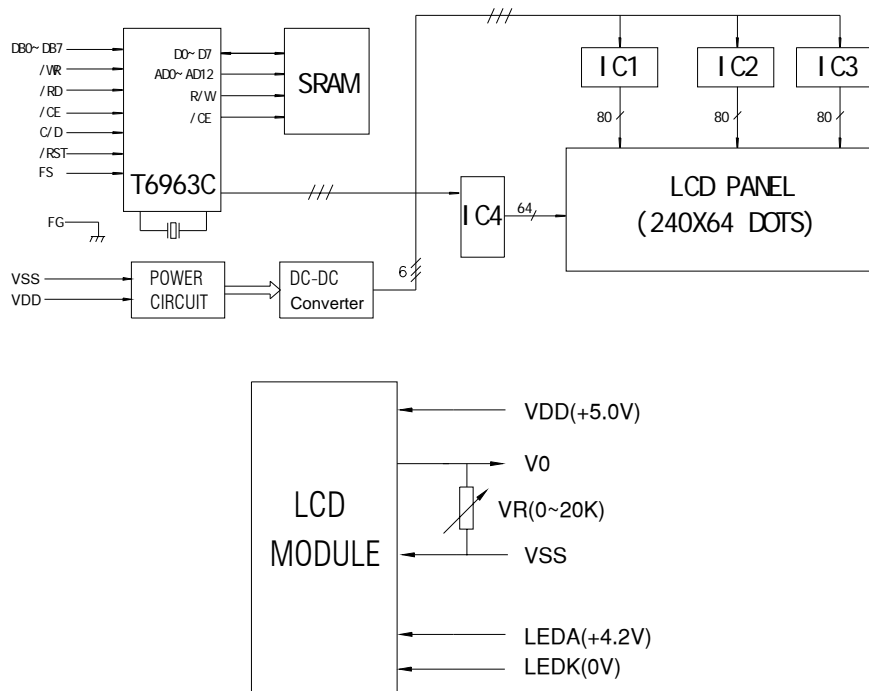

Figure 1. Block diagram

4. DIMENSIONAL OUTLINE

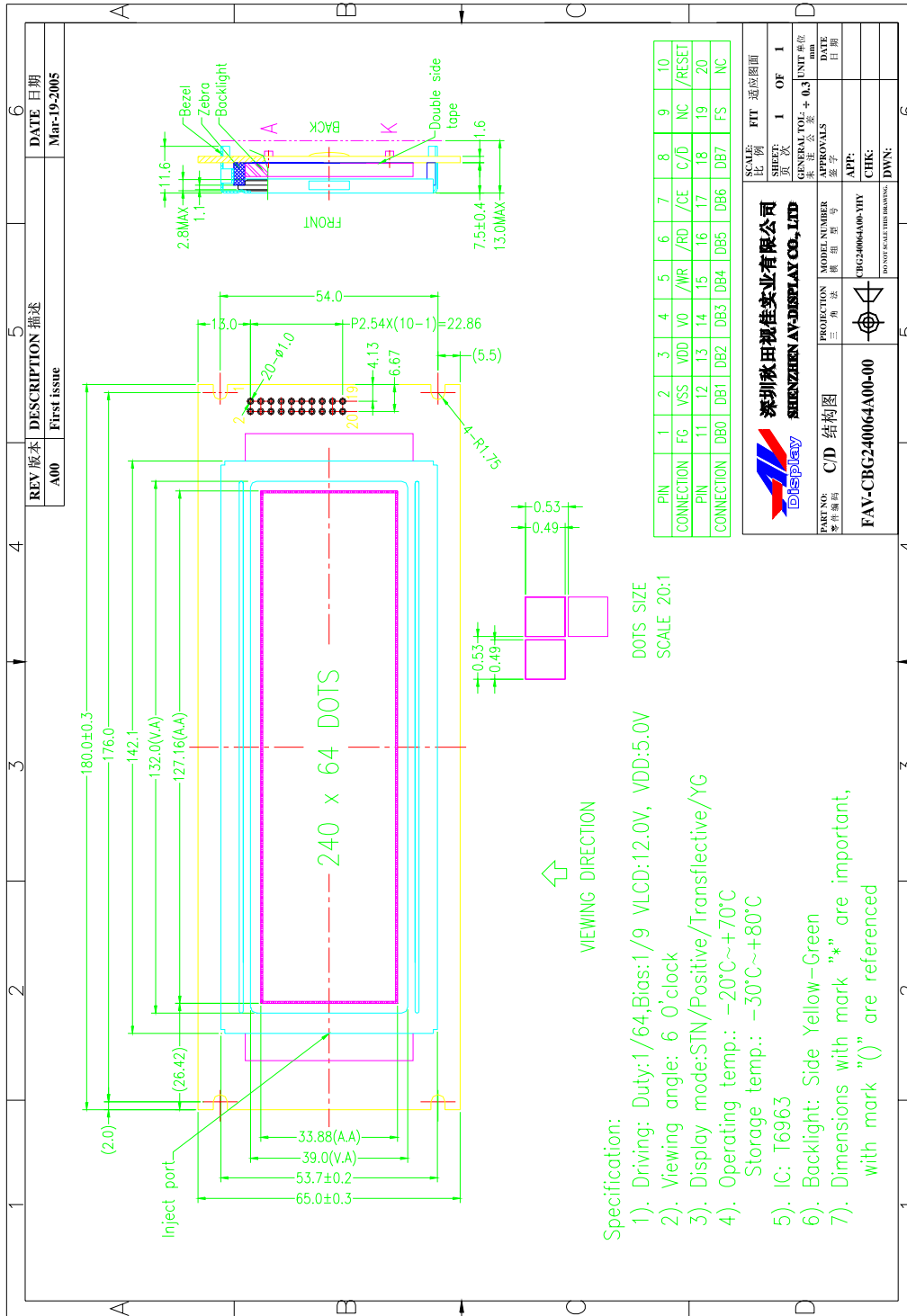

Figure 2. Dimensional outline



5. PIN DESCRIPTION

No.	Symbol	Function
1	FG	Frame GND
2	VSS	GND(0V)
3	VDD	Power supply for the logic (+5V)
4	V0	Power supply for the LCD drive
5	/WR	Write signal
6	/RD	Read signal
7	/CE	Chip enable signal
8	C/D	Data or Instruction select signal
9	NC	NO Connection
10	/RESET	Reset signal
11-18	DB0~DB7	Data bus line
19	FS	Font selection terminal
20	NC	NO Connection

6. MAXIMUM ABSOLUTE LIMIT

For T6963C:

($V_{SS}=0V, T_r=25\text{ }^\circ\text{C}$)

Item	Symbol	Value	Units
Power supply voltage	V_{DD}	-0.3 to +7.0	V
Input voltage	V_{in}	-0.3 to $V_{DD}+0.3$	V
Operating Temperature	T_{op}	-10 to +70	$^\circ\text{C}$
Storage Temperature	T_{stg}	-55 to +125	$^\circ\text{C}$

Note: Specification is for T6963C only. LCD module specifications may differ.

CBG24064A14 VEE supply

www.FindLCD.com

Pin No.	Symbol	Function
1	FG	Frame GND
2	VSS	GND(0V)
3	VDD	Power supply for the logic (+5V)
4	V0	Power supply for the LCD drive
5	WR	Write signal
6	RD	Read signal
7	CE	Chip enable signal
8	C/D	Instruction(C/D=H) or Data(C/D=L) select signal
9	NC	N/C or VEE by solder short J6-2 on PCB.
10	RST	Reset signal
11-18	DB0~DB7	Data bus line
19	FS	Font selection terminal
20	NC	N/C or VEE by solder short J6-1 on PCB.
LEDA	LEDA	Power supply for Backlight(+) :3.0V~3.4V (Typ:3.2V), 120mA
LEDK	LEDK	Power supply for Backlight(-) (White color)

LCDvop spec:

Item	Symbol	Condition	Min	Typ	Max	Unit
Operating Voltage	Vop	Ta = -20C	12.2	12.5	12.8	V
		Ta = 25°C	11.7	12.0	12.3	
		Ta = 70C	11.2	11.5	11.8	

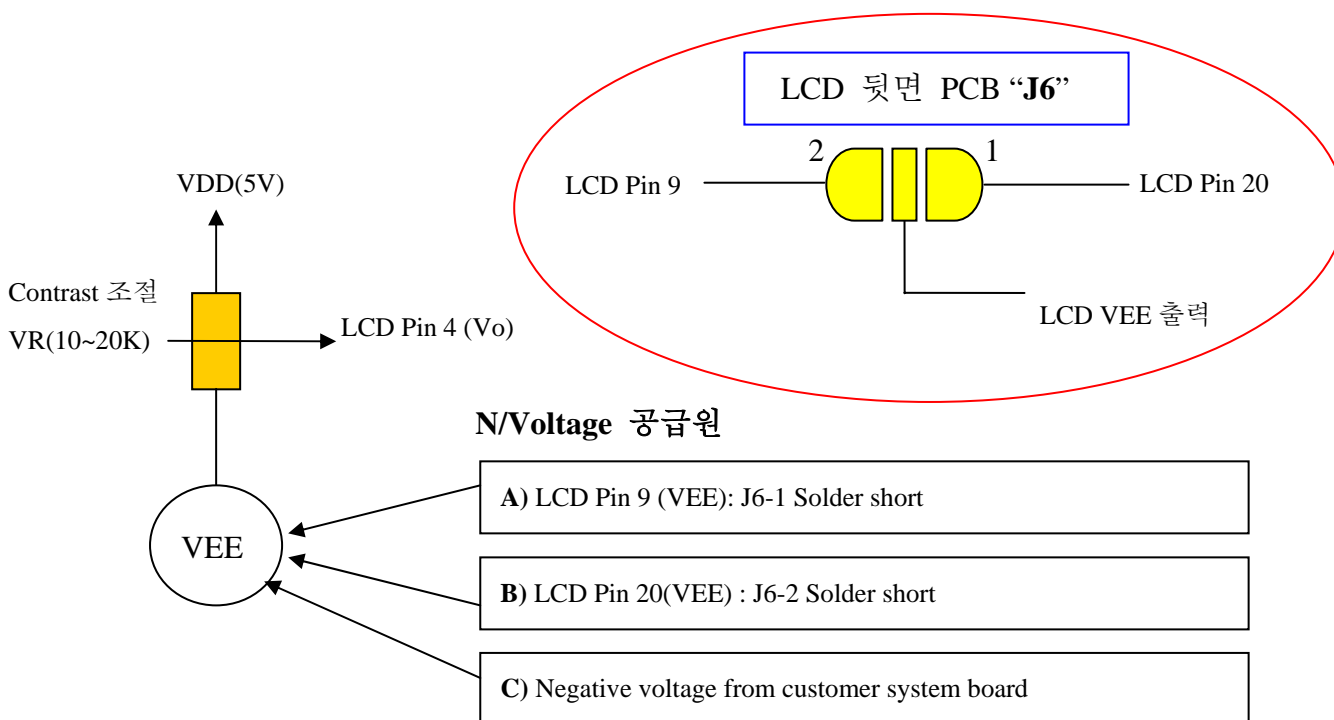

LCDvop 는 상기의 A,C,B 중에 한 가지만 반드시 공급해야 하며 Contrast 조절 Volume 으로 조절하여 LCD 의 Vo pin(pin 4)에 12V 정도를 공급하면 적절한 밝기의 Contrast 가 될 것입니다.

LCD 내부 N/V 사용시 LCD Pin 9, 20 을 확인하시어 J6 Solder short 하여 사용하시기 바랍니다.

LCD 외부의 N/V 사용시 J6 을 모두 Open 하시기 바랍니다.

7. ELECTRICAL CHARACTERISTICS

($V_{DD}=+5V\pm 5\%$, $GND=0V$, $T_a=+25^\circ C$)

Item	Symbol	Condition	Min	Max	Units	Notes
Operating Voltage	V_{DD}		4.5	5.5	V	
Input voltage	"H"	V_{IH}	$V_{DD}-2.2$	V_{DD}	V	1, 3
	"L"	V_{IL}	0	0.8	V	1, 2, 3
Output voltage	"H"	V_{OH}	$V_{DD}-0.3$	V_{DD}	V	3
	"L"	V_{OL}	0	0.3	V	3
Output Resistance	"H"	R_{OH}	$V_{OUT}=V_{DD}-0.5$	400	Ω	3
	"L"	R_{OL}	$V_{OUT}=0.5$	400	Ω	3
Current	Oper.	$I_{DD}(1)$	$V_{DD}=5.0V$ $f_{osc}=3.0\text{ MHz}$	6	mA	
Consumption	Halt	$I_{DD}(2)$		3	μA	
Input leakage current	I_{IL}	$V_{in}=0\sim V_{DD}$	-5	5	μA	3
Output leakage current	I_{OL}	$V_{out}=0\sim V_{DD}$	-10	10	μA	3
Internal Oscillation	f_{osc}		0.4	5.5	MHz	
External clock frequency	f_{cp}		-	2750	KHz	
Ext. clock rise/fall time	t_{rep}, t_{fcp}		-	30	ns	

Notes:

- \overline{CE} , $\overline{C/D}$, \overline{RD} , \overline{WR}
- \overline{RES}
- DB0 to DB7

8. The /RES (RESET) Terminal

The T6963C may be reset by an external active low TTL signal from a MPU or other logic device or it may be reset using the following circuit.

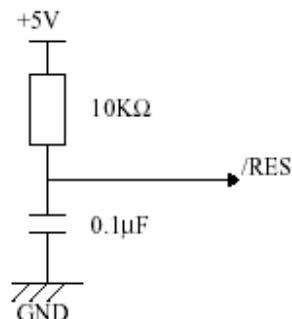

9. TIMING CHARACTERISTICS



MPU Interface Timing (MPU \leftrightarrow T6963C)

Item	Symbol	Min	Typ	Max	Unit
$\overline{C/D}$ Set Up Time	t_{CDS}	100	-	-	ns
$\overline{C/D}$ Hold Time	t_{CDH}	10	-	-	ns
\overline{CE} , \overline{RD} , \overline{WR} Pulse Width	t_{CE} , t_{RD} , t_{WR}	80	-	-	ns
Data Set Up Time	t_{DS}	80	-	-	ns
Data Hold Time	t_{DH}	40	-	-	ns
Access time	t_{ACC}	-	-	150	ns
Output Hold Time	t_{OH}	10	-	50	ns

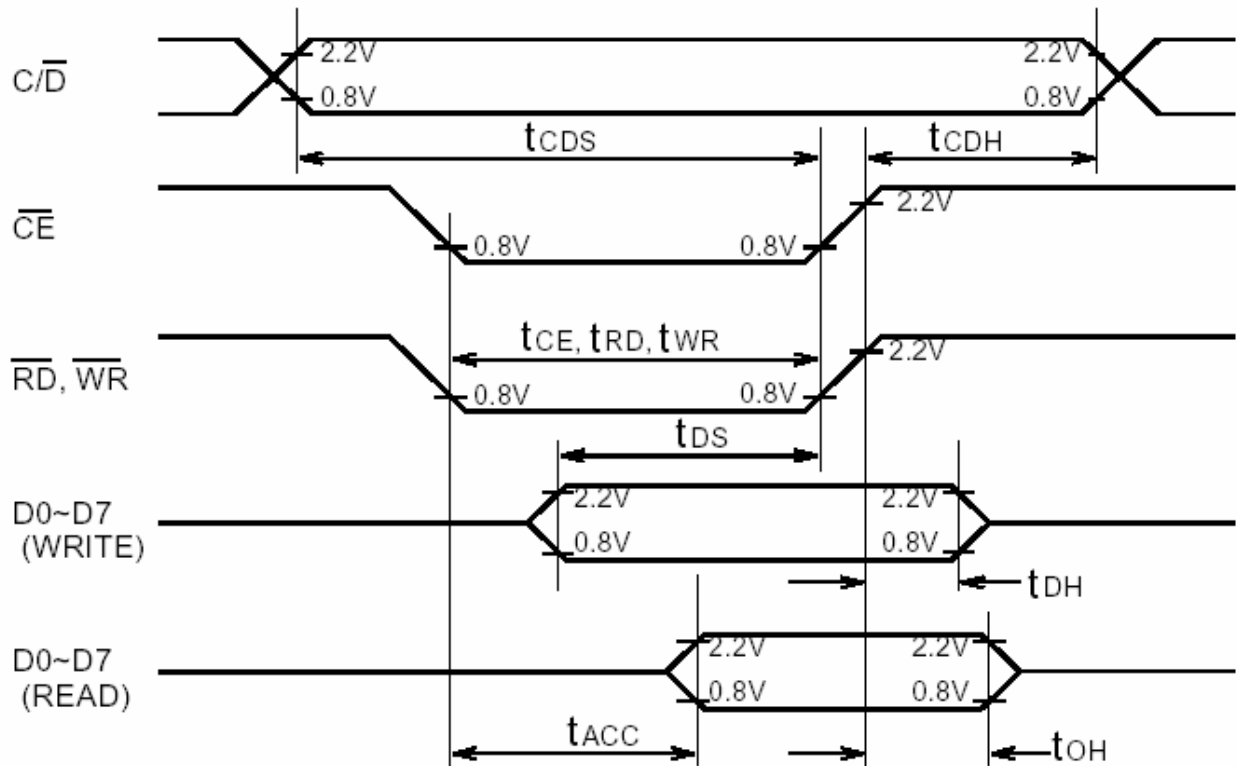

10. CONTROL AND DISPLAY INSTRUCTION

Commands	D7 D6 D5 D4 D3 D2 D1 D0								Description	Execute Time
	D7	D6	D5	D4	D3	D2	D1	D0		
Pointer Set	0	0	1	0	0	N2	N1	N0		Status check
						0	0	1	Cursor Pointer Set	
						0	1	0	Offset Register Set	
						1	0	0	Address Pointer Set	
Control Word Set Commands	0	1	0	0	0	0	N1	N0		32 x 1/fosc
							0	0	Text Home Address Set	
							0	1	Text Area Set	
							1	0	Graphic Home Address Set	

findLED

Note:

1. * = DONT CARE



2. Read the status of the STA0 and STA1 Flags before each new command or data byte is sent to the T6963C. If these two flags are set (i.e.=1) then the T6963C is not busy processing the previous instruction and it is safe to write a new command or data byte to the T6963C. If a new instruction is sent to the T6963C while these two flags are not set (i.e.=0), then that command shall be ignored by the T6963C.
3. In the case of a dual screen LCD the screen copy command should not be used.

11. Recommended Initialization

The Mode Set and Control Word Set commands must be initialized after power is turned ON. These command define what size display the T6963C is to control and which mode to run in.

Commands	C/D	D7	D6	D5	D4	D3	D2	D1	D0	Hex	Description
Power On.	Power On										
Hard Reset (/RES)	/RES="L" (1 msec min. After $V_{DD}>4.75V$)										
Mode Set	1	1	0	0	0	0	0	0	0	80H	"OR", "CG-ROM" Mode
Control Word Set	0	0	0	0	0	0	0	0	0	00H	Graphic Home address data
	0	0	0	0	0	0	0	0	0	00H	GH=0000H
Graphic Home Address Set	1	0	1	0	0	0	0	1	0	42H	Graphic Home Address Set command
Control Word Set	0	*	*	*	*	*	*	*	*	*	See section 10.1.2 for value of GA data
	0	*	*	*	*	*	*	*	*	*	
Graphic Home Address Set	1	0	1	0	0	0	0	1	1	43H	Graphic Area Set command
Control Word Set	0	*	*	*	*	*	*	*	*	*	See section 10.1.2 for value of TH data
	0	*	*	*	*	*	*	*	*	*	TH=****H
Text Home Address Set	1	0	1	0	0	0	0	0	0	40H	Text Home Address Set command
Control Word Set	0	*	*	*	*	*	*	*	*	*	See section 10.1.2 for value of TA data
	0	*	*	*	*	*	*	*	*	*	TA=****H
Text Home Address Set	1	0	1	0	0	0	0	0	1	41H	Text Area Set command
Initialisation Ends----- -	----- -----										
Address Pointer Set	0	*	*	*	*	*	*	*	*	*	Text Home address data (section 10.1.2)
	0	*	*	*	*	*	*	*	*	*	TH=****H
	1	0	0	1	0	0	1	0	0	24H	Address Pointer Set command
Data Write (Text) D	0	0	0	1	0	0	1	0	0	24H	Character code 24H="D"
	1	1	1	0	0	0	0	0	0	C0H	Data Write Autoincrement
Data Write (Text) E	0	0	0	1	0	0	1	0	1	25H	Character code 25H="E"
	1	1	1	0	0	0	0	0	0	C0H	Data Write Autoincrement
Data Write (Text) N											
	0	0	0	1	0	0	1	0	1	2EH	Character code 2EH="N"
Display Mode Set (Text/Graphics ON)	1	1	1	0	0	0	0	0	0	C0H	Data Write Autoincrement
	1	1	0	0	1	1	1	0	0	9CH	Display Mode Set command

12. BACK LIGHT CHARACTERISTICS



LCD Module with side LED Backlight
ELECTRICAL RATINGS

Ta = 25°C

Item	Symbol	Condition	Min	Typ	Max	Unit
Forward Voltage	IF	VF=2.0V	---	90	120	mA
Reverse Current	IR	VR=4.0V	---	0.2	---	mA
Luminous Intensity (With LCD dots off)	IV	IF=90mA	---	40	---	Cd/m ²
Wave length	λp	---	---	572	---	nm
Color	Yellow-green					

13. ELECTRO-OPTICAL CHARACTERISTICS

(V_{OP}=12.0V, Ta = 25°C)

Item	Symbol	Condition	Min	Typ	Max	Unit
Operating Voltage	Vop	Ta = -20°C	12.3	12.5	12.7	V
		Ta = 25°C	11.8	12.0	12.2	
		Ta = 70°C	11.3	11.5	11.7	
Response time	Tr	Ta = 25°C	---	185	---	ms
	Tf		---	200	---	ms
Contrast	Cr	Ta = 25°C	---	4	---	---
Viewing angle range	θ	Cr ≥ 2	-40	---	+40	deg
	Φ		-40	---	+40	deg

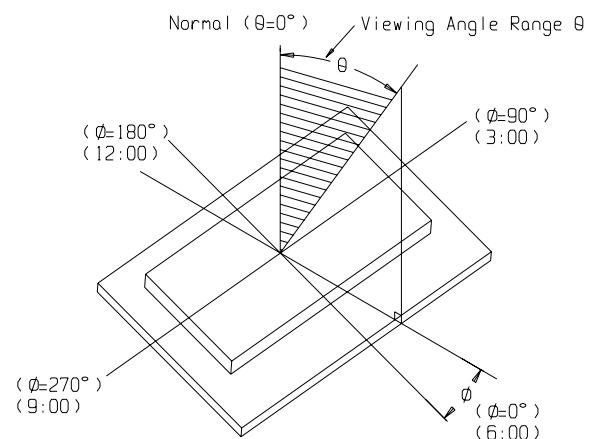
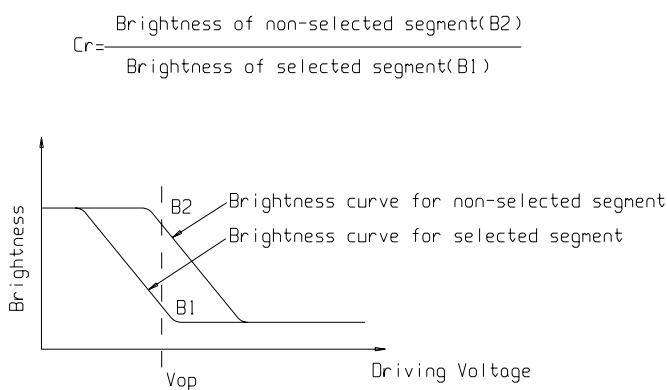



14.QUALITY SPECIFICATIONS

14.1 Standard of the product appearance test

Manner of appearance test: The inspection should be performed in using 20W x 2 fluorescent lamps. Distance between LCM and fluorescent lamps should be 100 cm or more. Distance between LCM and inspector eyes should be 30 cm or more.

Viewing direction for inspection is 45° from vertical against LCM.

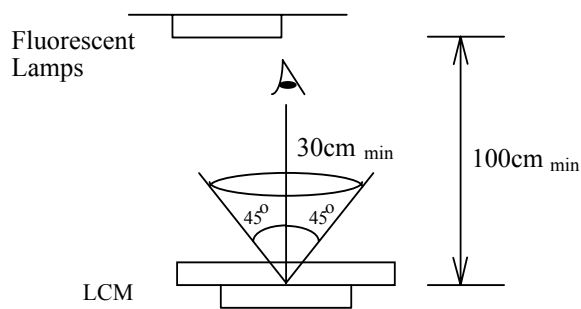

Definition of zone:

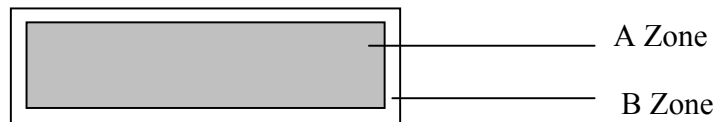

A Zone: Active display area (minimum viewing area).

B Zone: Non-active display area (outside viewing area).

14.2 Specification of quality assurance

AQL inspection standard

Sampling method: MIL-STD-105E, Level II, single sampling

Defect classification (**Note: * is not including**)



Classify	Item		Note	AQL
Major	Display state	Short or open circuit	1	0.65
		LC leakage		
		Flickering		
		No display		
		Wrong viewing direction		
		Contrast defect (dim, ghost)	2	
	Back-light	1,8		
	Non-display	Flat cable or pin reverse	10	
Wrong or missing component		11		
Minor	Display state	Background color deviation	2	1.0
		Black spot and dust	3	
		Line defect, Scratch	4	
		Rainbow	5	
		Chip	6	
		Pin hole	7	
	Polarizer	Protruded	12	
		Bubble and foreign material	3	
	Soldering	Poor connection	9	
	Wire	Poor connection	10	
	TAB	Position, Bonding strength	13	

Note on defect classification

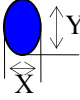
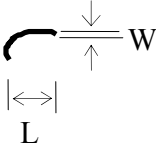
No.	Item	Criterion																				
1	Short or open circuit	Not allow																				
	LC leakage																					
	Flickering																					
	No display																					
	Wrong viewing direction																					
	Wrong Back-light																					
2	Contrast defect	Refer to approval sample																				
	Background color deviation																					
3	Point defect, Black spot, dust (including Polarizer) $\phi = (X+Y)/2$	 <table border="1" data-bbox="917 990 1340 1281"> <thead> <tr> <th>Point Size</th> <th>Acceptable Qty.</th> </tr> </thead> <tbody> <tr> <td>$\phi \leq 0.10$</td> <td>Disregard</td> </tr> <tr> <td>$0.10 < \phi \leq 0.20$</td> <td>3</td> </tr> <tr> <td>$0.20 < \phi \leq 0.25$</td> <td>2</td> </tr> <tr> <td>$0.25 < \phi \leq 0.30$</td> <td>1</td> </tr> <tr> <td>$\phi > 0.30$</td> <td>0</td> </tr> </tbody> </table> <p>Unit: mm</p>	Point Size	Acceptable Qty.	$\phi \leq 0.10$	Disregard	$0.10 < \phi \leq 0.20$	3	$0.20 < \phi \leq 0.25$	2	$0.25 < \phi \leq 0.30$	1	$\phi > 0.30$	0								
Point Size	Acceptable Qty.																					
$\phi \leq 0.10$	Disregard																					
$0.10 < \phi \leq 0.20$	3																					
$0.20 < \phi \leq 0.25$	2																					
$0.25 < \phi \leq 0.30$	1																					
$\phi > 0.30$	0																					
4	Line defect, Scratch	 <table border="1" data-bbox="845 1444 1380 1702"> <thead> <tr> <th colspan="2">Line</th> <th>Acceptable Qty.</th> </tr> <tr> <th>L</th> <th>W</th> <th></th> </tr> </thead> <tbody> <tr> <td>---</td> <td>$0.015 \geq W$</td> <td>Disregard</td> </tr> <tr> <td>$3.0 \geq L$</td> <td>$0.03 \geq W$</td> <td rowspan="2">2</td> </tr> <tr> <td>$2.0 \geq L$</td> <td>$0.05 \geq W$</td> </tr> <tr> <td>$1.0 \geq L$</td> <td>$0.1 > W$</td> <td>1</td> </tr> <tr> <td>---</td> <td>$0.05 < W$</td> <td>Applied as point defect</td> </tr> </tbody> </table> <p>Unit: mm</p>	Line		Acceptable Qty.	L	W		---	$0.015 \geq W$	Disregard	$3.0 \geq L$	$0.03 \geq W$	2	$2.0 \geq L$	$0.05 \geq W$	$1.0 \geq L$	$0.1 > W$	1	---	$0.05 < W$	Applied as point defect
Line		Acceptable Qty.																				
L	W																					
---	$0.015 \geq W$	Disregard																				
$3.0 \geq L$	$0.03 \geq W$	2																				
$2.0 \geq L$	$0.05 \geq W$																					
$1.0 \geq L$	$0.1 > W$	1																				
---	$0.05 < W$	Applied as point defect																				
5	Rainbow	Not more than two color changes across the viewing area.																				

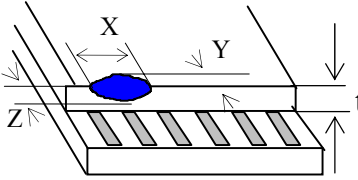
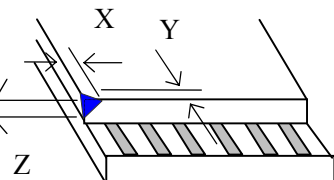
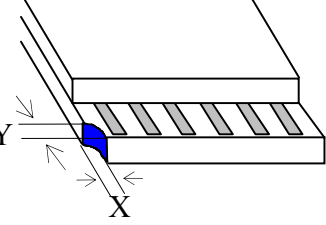
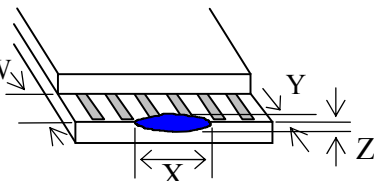
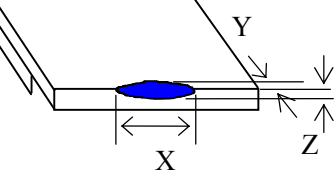
No	Item	Criterion																																	
6	<p>Chip</p> <p>Remark:</p> <p>X: Length direction</p> <p>Y: Short direction</p> <p>Z: Thickness direction</p> <p>t: Glass thickness</p> <p>W: Terminal Width</p>	 <p>Acceptable criterion</p> <table border="1" data-bbox="981 459 1364 537"> <thead> <tr> <th>X</th> <th>Y</th> <th>Z</th> </tr> </thead> <tbody> <tr> <td>≤ 2</td> <td>0.5mm</td> <td>$\leq t/2$</td> </tr> </tbody> </table>  <p>Acceptable criterion</p> <table border="1" data-bbox="973 761 1364 840"> <thead> <tr> <th>X</th> <th>Y</th> <th>Z</th> </tr> </thead> <tbody> <tr> <td>≤ 2</td> <td>0.5mm</td> <td>$\leq t$</td> </tr> </tbody> </table>  <p>Acceptable criterion</p> <table border="1" data-bbox="989 1041 1364 1153"> <thead> <tr> <th>X</th> <th>Y</th> <th>Z</th> </tr> </thead> <tbody> <tr> <td>≤ 3</td> <td>≤ 2</td> <td>$\leq t$</td> </tr> <tr> <td colspan="2">shall not reach to ITO</td> <td></td> </tr> </tbody> </table>  <p>Acceptable criterion</p> <table border="1" data-bbox="973 1411 1364 1489"> <thead> <tr> <th>X</th> <th>Y</th> <th>Z</th> </tr> </thead> <tbody> <tr> <td>Disregard</td> <td>≤ 0.2</td> <td>$\leq t$</td> </tr> </tbody> </table>  <p>Acceptable criterion</p> <table border="1" data-bbox="973 1691 1332 1769"> <thead> <tr> <th>X</th> <th>Y</th> <th>Z</th> </tr> </thead> <tbody> <tr> <td>≤ 5</td> <td>≤ 2</td> <td>$\leq t/3$</td> </tr> </tbody> </table>	X	Y	Z	≤ 2	0.5mm	$\leq t/2$	X	Y	Z	≤ 2	0.5mm	$\leq t$	X	Y	Z	≤ 3	≤ 2	$\leq t$	shall not reach to ITO			X	Y	Z	Disregard	≤ 0.2	$\leq t$	X	Y	Z	≤ 5	≤ 2	$\leq t/3$
X	Y	Z																																	
≤ 2	0.5mm	$\leq t/2$																																	
X	Y	Z																																	
≤ 2	0.5mm	$\leq t$																																	
X	Y	Z																																	
≤ 3	≤ 2	$\leq t$																																	
shall not reach to ITO																																			
X	Y	Z																																	
Disregard	≤ 0.2	$\leq t$																																	
X	Y	Z																																	
≤ 5	≤ 2	$\leq t/3$																																	

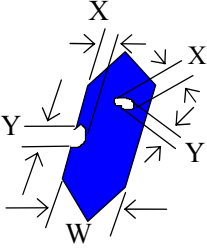
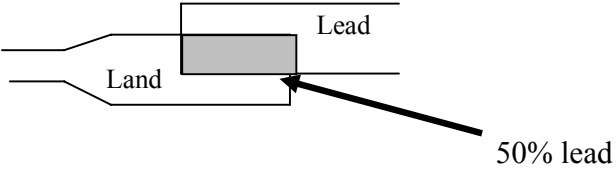
No.	Item	Criterion								
7	Segment pattern $W = \text{Segment width}$ $\phi = (X+Y)/2$	(1) Pin hole $\phi < 0.10\text{mm}$ is acceptable.  <table border="1" data-bbox="906 577 1358 752"> <thead> <tr> <th>Point Size</th> <th>Acceptable Qty</th> </tr> </thead> <tbody> <tr> <td>$\phi \leq 1/4W$</td> <td>Disregard</td> </tr> <tr> <td>$1/4W < \phi \leq 1/2W$</td> <td>1</td> </tr> <tr> <td>$\phi > 1/2W$</td> <td>0</td> </tr> </tbody> </table> <p style="text-align: center;">Unit: mm</p>	Point Size	Acceptable Qty	$\phi \leq 1/4W$	Disregard	$1/4W < \phi \leq 1/2W$	1	$\phi > 1/2W$	0
Point Size	Acceptable Qty									
$\phi \leq 1/4W$	Disregard									
$1/4W < \phi \leq 1/2W$	1									
$\phi > 1/2W$	0									
8	Back-light	(1) The color of backlight should correspond its specification. (2) Not allow flickering								
9	Soldering	(1) Not allow heavy dirty and solder ball on PCB. (The size of dirty refer to point and dust defect) (2) Over 50% of lead should be soldered on Land. 								
10	Wire	(1) Copper wire should not be rusted (2) Not allow crack on copper wire connection. (3) Not allow reversing the position of the flat cable. (4) Not allow exposed copper wire inside the flat cable.								
11*	PCB	(1) Not allow screw rust or damage. (2) Not allow missing or wrong putting of component.								

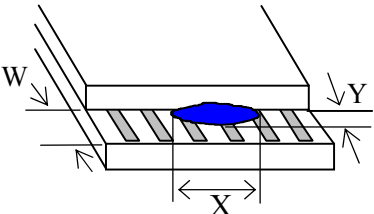
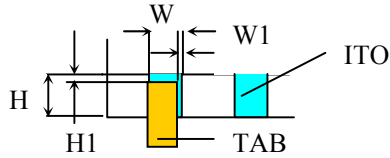
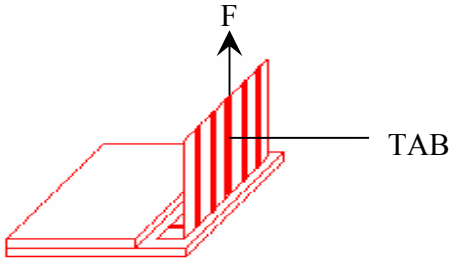
No	Item	Criterion
12	Protruded W: Terminal Width	 <p>Acceptable criteria: $Y \leq 0.4$</p>
13	TAB	<p>1. Position</p>  <div style="border: 1px solid black; padding: 5px; width: fit-content; margin-left: auto; margin-right: auto;"> $W1 \leq 1/3W$ $H1 \leq 1/3H$ </div> <p>2 TAB bonding strength test</p>  <p> $P (=F/TAB \text{ bonding width}) \geq 650\text{gf/cm}$,(speed rate: 1mm/min) 5pcs per SOA (shipment) </p>
14	Total no. of acceptable Defect	<p>A. Zone</p> <p>Maximum 2 minor non-conformities per one unit. Defect distance: each point to be separated over 10mm</p> <p>B. Zone</p> <p>It is acceptable when it is no trouble for quality and assembly in customer's end product.</p>



14.3 Reliability of LCM

Reliability test condition:

Item	Condition	Time (hrs)	Assessment
High temp. Storage	80°C	48	No abnormalities in functions and appearance
High temp. Operating	70°C	48	
Low temp. Storage	-30°C	48	
Low temp. Operating	-20°C	48	
Humidity	40°C/ 90%RH	48	
Temp. Cycle	0°C ← 25°C → 50°C (30 min ← 5 min → 30min)	10cycles	

Recovery time should be 24 hours minimum. Moreover, functions, performance and appearance shall be free from remarkable deterioration within 50,000 hours under ordinary operating and storage conditions room temperature ($20 \pm 8^\circ\text{C}$), normal humidity (below 65% RH), and in the area not exposed to direct sun light.

14.4 Precaution for using LCD/LCM

LCD/LCM is assembled and adjusted with a high degree of precision. Do not attempt to make any alteration or modification. The followings should be noted.

General Precautions:

1. LCD panel is made of glass. Avoid excessive mechanical shock or applying strong pressure onto the surface of display area.
2. The polarizer used on the display surface is easily scratched and damaged. Extreme care should be taken when handling. To clean dust or dirt off the display surface, wipe gently with cotton, or other soft material soaked with isopropyl alcohol, ethyl alcohol or trichlorotrifluoroethane, do not use water, ketone or aromatics and never scrub hard.
3. Do not tamper in any way with the tabs on the metal frame.
4. Do not make any modification on the PCB without consulting AV.
5. When mounting a LCM, make sure that the PCB is not under any stress such as bending or twisting. Elastomer contacts are very delicate and missing pixels could result from slight dislocation of any of the elements.



6. Avoid pressing on the metal bezel, otherwise the elastomer connector could be deformed and lose contact, resulting in missing pixels and also cause rainbow on the display.
7. Be careful not to touch or swallow liquid crystal that might leak from a damaged cell. Any liquid crystal adheres to skin or clothes, wash it off immediately with soap and water.

Static Electricity Precautions:

1. CMOS-LSI is used for the module circuit; therefore operators should be grounded whenever he/she comes into contact with the module.
2. Do not touch any of the conductive parts such as the LSI pads; the copper leads on the PCB and the interface terminals with any parts of the human body.
3. Do not touch the connection terminals of the display with bare hand; it will cause disconnection or defective insulation of terminals.
4. The modules should be kept in anti-static bags or other containers resistant to static for storage.
5. Only properly grounded soldering irons should be used.
6. If an electric screwdriver is used, it should be grounded and shielded to prevent sparks.
7. The normal static prevention measures should be observed for work clothes and working benches.
8. Since dry air is inductive to static, a relative humidity of 50-60% is recommended.

Soldering Precautions:

1. Soldering should be performed only on the I/O terminals.
2. Use soldering irons with proper grounding and no leakage.
3. Soldering temperature: $280^{\circ}\text{C} \pm 10^{\circ}\text{C}$
4. Soldering time: 3 to 4 second.
5. Use eutectic solder with resin flux filling.
6. If flux is used, the LCD surface should be protected to avoid spattering flux.
7. Flux residue should be removed.

Operation Precautions:

1. The viewing angle can be adjusted by varying the LCD driving voltage V_o .
2. Since applied DC voltage causes electro-chemical reactions, which deteriorate the display, the applied pulse waveform should be a symmetric waveform such that no DC component remains. Be sure to use the specified operating voltage.
3. Driving voltage should be kept within specified range; excess voltage will shorten display life.
4. Response time increases with decrease in temperature.
5. Display color may be affected at temperatures above its operational range.
6. Keep the temperature within the specified range usage and storage. Excessive temperature and humidity could cause polarization degradation, polarizer peel-off or generate bubbles.
7. For long-term storage over 40°C is required, the relative humidity should be kept below 60%, and avoid direct sunlight.



Limited Warranty

FINDLCD LCDs and modules are not consumer products, but may be incorporated by AV's customers into consumer products or components thereof, FINDLCD does not warrant that its LCDs and components are fit for any such particular purpose.

1. The liability of FINDLCD is limited to repair or replacement on the terms set forth below. FINDLCD will not be responsible for any subsequent or consequential events or injury or damage to any personnel or user including third party personnel and/or user. Unless otherwise agreed in writing between FINDLCD and the customer, FINDLCD will only replace or repair any of its LCD which is found defective electrically or visually when inspected in accordance with FINDLCD general LCD inspection standard . (Copies available on request)
2. No warranty can be granted if any of the precautions state in handling liquid crystal display above has been disregarded. Broken glass, scratches on polarizer mechanical damages as well as defects that are caused accelerated environment tests are excluded from warranty.
3. In returning the LCD/LCM, they must be properly packaged; there should be detailed description of the failures or defect.