

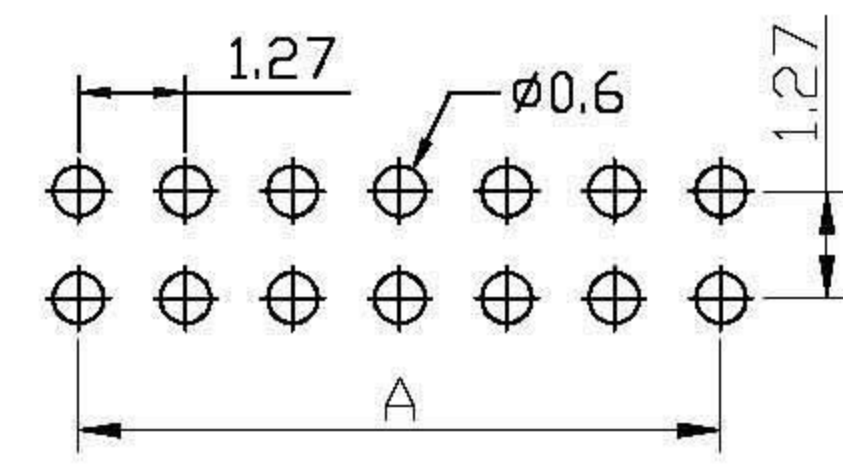

No. of Contacts	DIMENSIONS	
	A	B
2	1.27	2.54
3	2.54	3.81
4	3.81	5.08
5	5.08	6.35
6	6.35	7.62
7	7.62	8.89
8	8.89	10.16
9	10.16	11.43
10	11.43	12.70
11	12.70	13.97
12	13.97	15.24
13	15.24	16.51
14	16.51	17.78
15	17.78	19.05
16	19.05	20.32
17	20.32	21.59
18	21.59	22.86
19	22.86	24.13
20	24.13	25.40
21	25.40	26.67
22	26.67	27.94
23	27.94	29.21
24	29.21	30.48
25	30.48	31.75
26	31.75	33.02
27	33.02	34.29
28	34.29	35.56
29	35.56	36.83
30	36.83	38.10
31	38.10	39.37
32	39.37	40.64
33	40.64	41.91
34	41.91	43.18
35	43.18	44.45
36	44.45	45.72
37	45.72	46.99
38	46.99	48.26
39	48.26	49.53
40	49.53	50.80
50	62.23	63.50

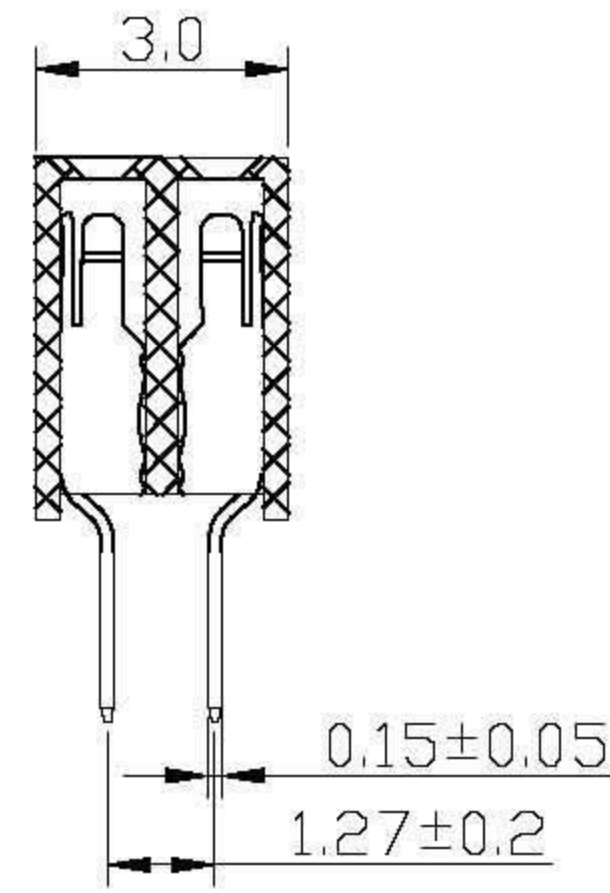
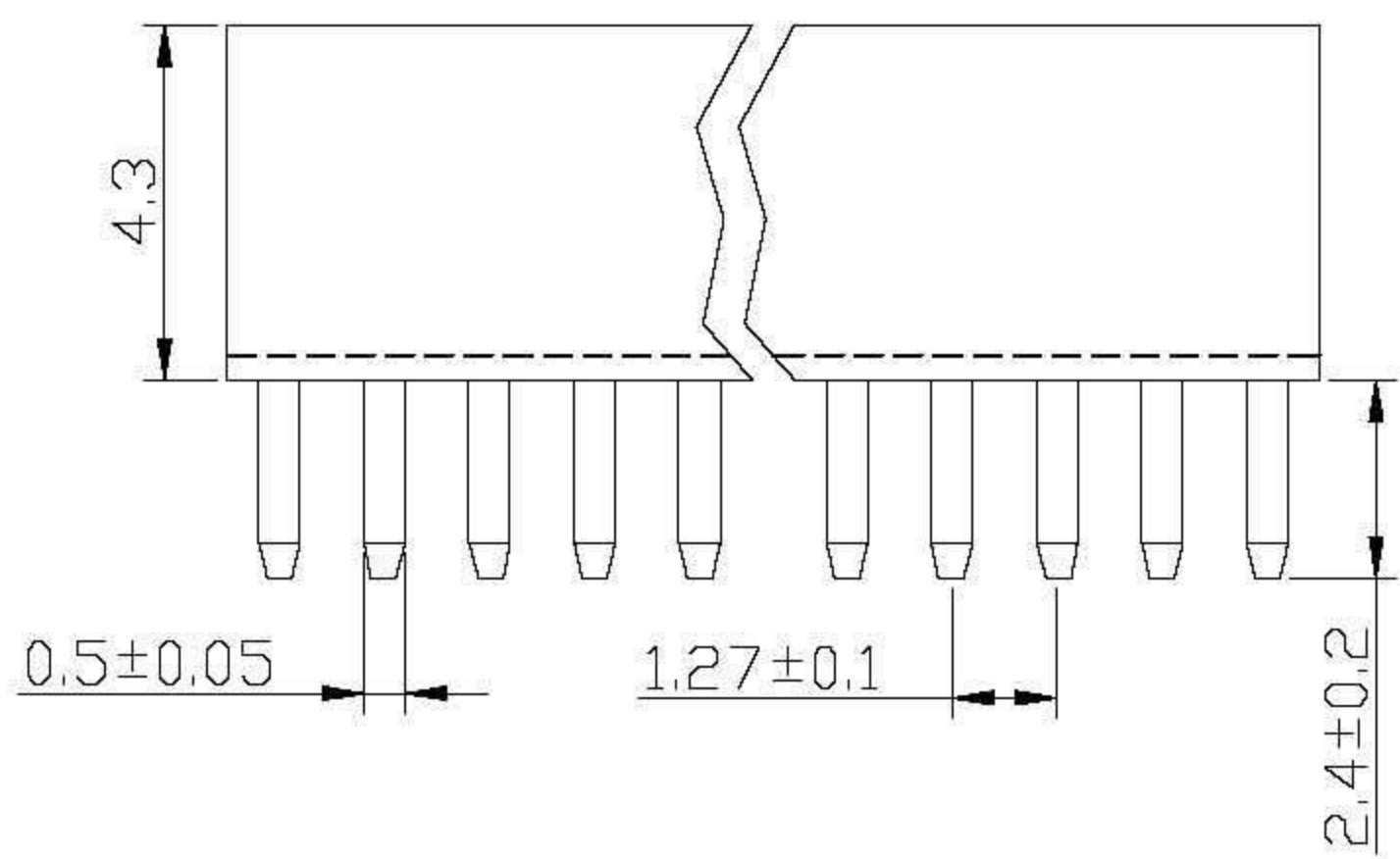
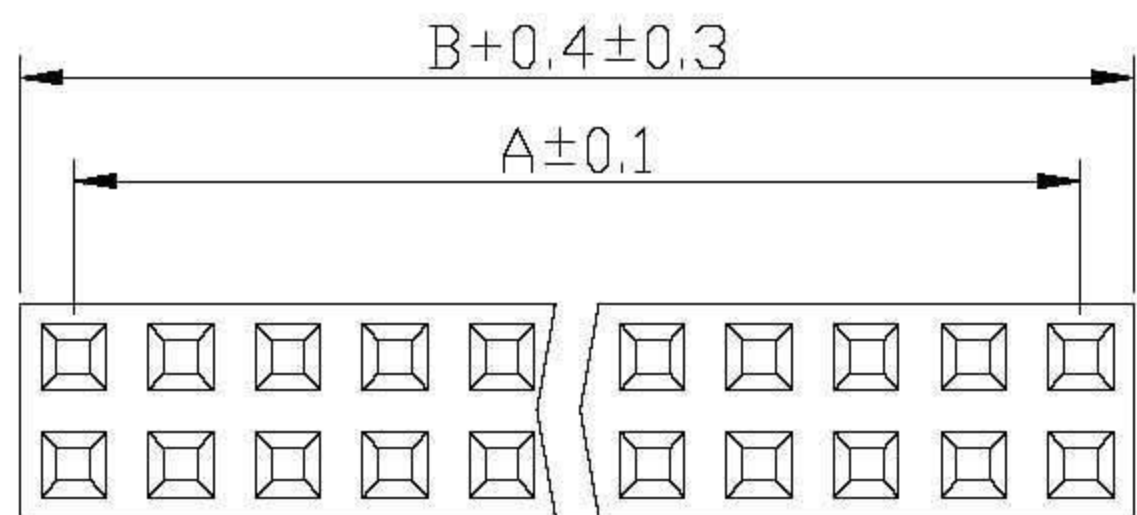

SPECIFICATIONS

- Insulator Material: Polyester (UL94V-0)
- Current Rating: 1AMP
- Contact Resistance: 20 mΩ Max
- Insulation Resistance: 1000 mΩ min
- Withstanding Volage: AC 500V
- Contact Material: Phosphor bronze
- Standard: PA6T
- Operating Temperature: -40°C to+ 105°C
- Max.Processing Temp: 230°C for30-60seconds (260°C for10seconds)

Recommended P.C.B Hole Layout

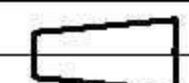
UNLESS OTHEWIXE SPECIFIED TOLERANCE			
x.	±0.3	x.*	±5'
x.x	±0.2	x.x*	±1'
x.xx	±0.1	x.xx*	±0.5'
SCALE		UNIT	
		mm	
DRAWN		15/04/09	
LI BEI LIN		DRAWM NAME	
CHECKED		Female header 1.27mm	
APPROVED		PROUCT NO.	
/ /		PILE NAME:	
 		SIZE	REV
		A4	A

1.27PF 2*nPin H4.3 DIP PC2.4